

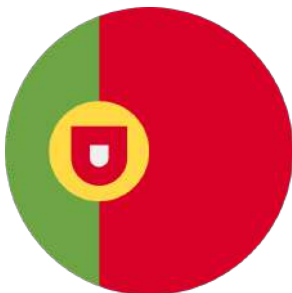

***Choose your language
and click on your flag***





ATTENTION

INFORMATION

1/ CONTRÔLER LA RÉCEPTION DANS LES 48 H :

- Assurez-vous que vous avez reçu le bon produit. Présentez la capote sur votre ancienne capote et assurez-vous que le produit soit à la bonne dimension et avec les mêmes particularités que la capote en place.

Nous vous rappelons qu'aucun article présentant des traces de colle ou des traces de pose ne sera repris

- Déplier la capote et la laisser se détendre dans une température proche de 20°.
- Si la capote ne possède pas tous les accessoires que la capote origine en tenir compte au remontage.

2 / CONTRÔLE DE L'ÉTAT DES POIGNÉES DE FERMETURE :

- Contrôlez que vos poignées ne soient pas fendues :
En effet lors de la mise en place de la capote neuve, la mise sous tension est toujours difficile et nécessite une traction importante sur les poignées. Cette traction diminuera très rapidement lorsque la capote aura pris sa place.

3/ CAPOTES ÉLECTRIQUES :

AVANT DÉMONTAGE

- Contrôler que le système fonctionne parfaitement, que le niveau d'huile est satisfaisant et que la batterie est bien chargée.

AVANT REMONTAGE (capote démontée)

- Contrôler le fonctionnement de l'arceau.
- Procéder au nettoyage et lubrifier tous les axes.
- Changer tous les élastiques qui sont relâchés.
- Contrôler que les différents arceaux se plient normalement dans le coffre à capote au décapotage.
- Si nécessaire changer toutes les sangles.

Si vous ne respectez pas ces points, l'arceau peut trouer la capote.

4/ PRODUITS NON TENUS EN STOCK ou COMMANDE SPÉCIALE :

- Les commandes spéciales et les produits non tenus en stock ne sont ni repris ni échangés.
- Pour les autres produits tenus en stock, les frais de retour sont à votre charge ainsi que les frais de contrôle et de reconditionnement éventuels.
- Le produit doit être à l'état neuf avec les transparents non rayés dans son emballage d'origine.

Vous aimerez aussi...



CAPOTES



WINDSCHOTTTS



PORTE-BAGAGES



BAGAGERIES



SELLERIES



CONSEIL ENTRETIEN

CAPOTAGE

Vous venez de faire l'acquisition d'un produit de qualité, dont vous apprécierez les qualités à condition qu'il soit entretenu avec soin.

Pour cela nous vous conseillons d'observer les indications suivantes :

Entretenez votre arceau

Quand l'ancienne capote est démontée, vérifiez le fonctionnement et le graissage de l'arceau pour ne pas abîmer le nouveau capotage.

Tous les trimestres contrôlez le fonctionnement et le graissage de votre arceau en utilisant le Dégrissant.

Lavage de votre capote

Ne pas laver les capotes au lavage automatique à rouleaux.

Le lavage des capotes doit se faire à l'ombre, à l'eau froide.

Après avoir copieusement mouillé la capote, nous vous conseillons de pulvériser les nettoyeurs RENOVO (Réf DC01037 ou DC01038) et de brosser la capote avec la brosse souple.

Bien rincer ensuite.

Toujours laver la capote dans son intégralité afin d'éviter des auréoles.

Maintenir la capote fermée jusqu'au séchage complet.

Ne pas utiliser de nettoyant chimiques contenant Acétone, Alcool à brûler, Essence sous toute ses formes, diluant, dégraissant, solvants...

N'utiliser que les produits que nous commercialisons et dont nous garantissons le résultat et la sécurité.

Entretien de la lunette arrière en cristal souple

Déverrouiller la capote à l'avant, avant de manipuler la fermeture éclair.

Ne pas utiliser de nettoyant chimiques contenant Acétone, Alcool à brûler, Essence sous toute ses formes, diluant, dégraissant, solvants...

Ne pas manipuler votre capotage quand la température est en dessous de 10°. Vous risquez de fendre la lunette arrière souple.

Si le mécanisme est électrique, nous vous conseillons de contrôler à mi course que la lunette souple se plie correctement.

Laver la lunette à l'eau claire en utilisant les manchons à lustrer.

Nettoyer et effacer les micros rayures, en utilisant les manchons à lustrer pour appliquer le rénovateur vitres souples sur les 2 faces.

Manipulation de votre capotage

Avant de replier votre capote dans son coffre, contrôler qu'elle soit propre et parfaitement sèche. Vous éviterez le rétrécissement, les taches d'humidité et les rayures sur la lunette arrière souple.

Etanchéité, rénovation, recoloration

N'utiliser que les produits que nous commercialisons et qui ont faits leur preuve.

Vous trouverez au dos de ce document, les Kits qui reprennent tous les produits détaillés dans notre catalogue.

Vous aimerez aussi...



CAPOTES



WINDSCHOTTS



PORTE-BAGAGES

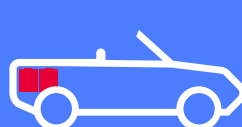

BAGAGERIES



SELLERIES



PRÉPARATION POSE

POSE DE CAPOTE

1/ CONTRÔLER LA RÉCEPTION:

Assurez-vous que vous avez reçu le bon produit :

Présenter la capote sur votre ancienne capote et assurez vous que le produit soit à la bonne dimension et avec les mêmes particularités que la capote en place.

NOUS VOUS RAPPELONS QU'AUCUN ARTICLE PRÉSENTANT DES TRACES DE COLLE OU DES TRACES DE POSE NE SERA REPRIS.

2 / PRÉPARATION DE L'OUTILLAGE :

Riveteuse et rivets assortis.

Colle néoprène et pinceau.

Un mètre à ruban et une craie.

Un marteau et une cale en bois.

Cutter grande lame et petite lame.

Pince universelle

Clé plates : 8/10/11/12/13.

Clé à pipe : 8/10/11/12/13.

Tournevis plats et cruciforme.

3 / CONTRÔLE DE L'ÉTAT DES POIGNÉES DE FERMETURE :

Contrôlez que vos poignées ne soient pas fendues :

En effet lors de la mise en place de la capote neuve, la mise sous tension est toujours difficile et nécessite une traction importante sur les poignées. Cette traction diminuera très rapidement lorsque la capote aura pris sa place.

4 / MISE EN PLACE DES CAPOTES EN PVC :

Les capotes en PVC doivent être mises en place dans une ambiance tiède pour pouvoir avoir une bonne souplesse lors de la pose.

L'été, il suffit de la laisser au soleil.

L'hiver, il faudra la chauffer avec un pistolet thermique (distance mini 20cm. A moins de pouvoir utiliser une cabine de peinture).

PREMIERE FERMETURE DE LA CAPOTE PVC : Elle sera difficile, il faudra peut être deux personnes pour fermer la capote. Cela est normal. Le lendemain elle aura pris sa place et la manoeuvre d'ouverture ou de fermeture s'effectuera sans problème.

5 / LUNETTE ARRIÈRE SOUPLE

Si des traces de pliages sont présentes sur le transparent souple, vous pouvez les éliminer en procédant ainsi :

Avec un sèche-cheveux placés à 25 cm minimum, réchauffer la partie qui porte un pli en procédant par mouvements circulaires.

Dés que la lunette devient souple arrêtez de chauffer ;

Laissez refroidir la lunette tout en tirant sur la toile qui borde la lunette souple afin de tendre la lunette souple, et effacez le pli.

Vous aimerez aussi...



CAPOTES



WINDSCHOTTS



PORTE-BAGAGES

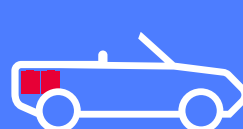

BAGAGERIES



SELLERIES



NOTICE DE MONTAGE

BMW E30 1985 - 1993

AVERTISSEMENT IMPORTANT:

- Lire l'intégralité du document avant de commencer le montage
- Ce document ayant été réalisé pour des professionnels expérimentés, certaines étapes du montage ne sont pas décrites
- La garantie ne couvrira pas les dégâts causés par une mauvaise installation
- **L'installation par un professionnel est fortement recommandée**
- Lors du démontage, conservez consciencieusement toutes les pièces et notez leur position d'origine, elles vous seront indispensables lors du montage de la nouvelle capote.
- Inspectez la capote avant son montage, s'il existe des imperfections dans le matériau contactez votre service client, **vosre capote ne sera ni reprise ni échangée après montage.**
- **Avant de procéder au montage, superposez les 2 capotes afin de vérifier que les dimensions et les profils correspondent parfaitement,** s'il existe une différence contactez votre service client

VOUS DEVEZ IMPÉRATIVEMENT CHANGER LES SANGLES LORS DU REMPLACEMENT DES CAPOTES.

En effet les sangles usagés ne permettent pas un rangement de la capote dans le coffre à capote. Vous risquez que l'arceau troue la toile à capote.

Outillage nécessaire

- Tournevis
- Perceuse
- Riveteuse
- Clef à pipe de 7
- Cutter

Vous aimerez aussi...



CAPOTES



WINDSCHOTTS



PORTE-BAGAGES



BAGAGERIES



SELLERIES



NOTICE DE MONTAGE

Comptoir du
Cabriolet

BMW E30
1985 - 1993

DÉMONTAGE DE L'ANCIENNE CAPOTE

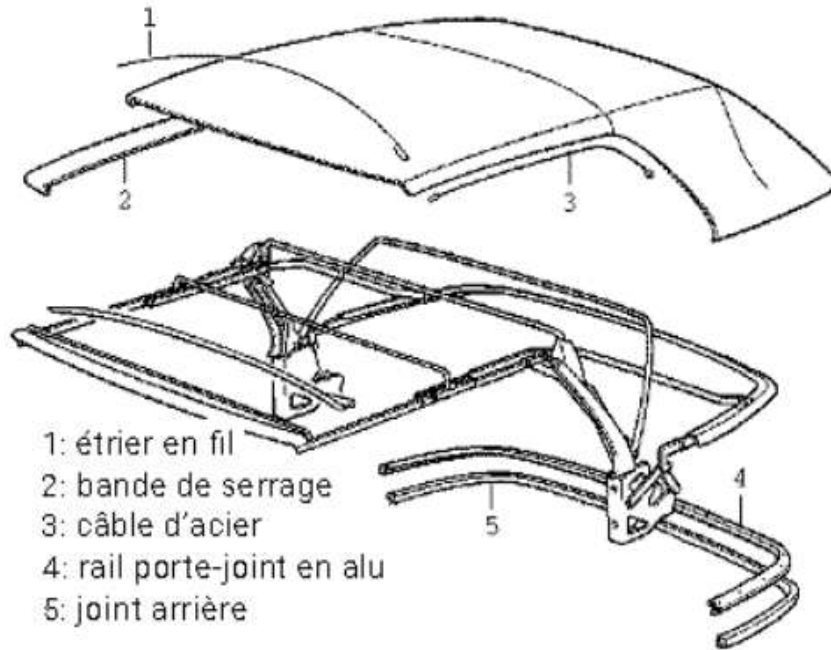

B1: rail avant (ref 54311932704)

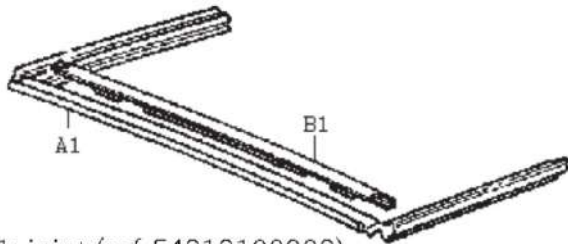

A1: joint (ref 54318100908)

A: rail
B: joint
C: équerre



Vous aimerez aussi...



CAPOTES



WINDSCHOTTIS



PORTE-BAGAGES



BAGAGERIES



SELLERIES



**Comptoir du
Cabriolet**



NOTICE DE MONTAGE

**BMW E30
1985 - 1993**

1

- Retirer le joint d'étanchéité (en U) de fermeture à l'avant (A1) en commençant par le dégager des rails au dessus des vitres latérales.
- Continuer par la partie avant de la casquette (utiliser un cutter si nécessaire pour couper le mastic de collage qui maintient le joint dans le rail alu (B1)).
- Retirer les 5 vis cruciformes sous le joint.
- Retirer la baguette (B1).
- Décoller la capote de la casquette.

2

- Retirer les câbles latéraux situés au dessus de la bordure.
- Décrocher les câbles en acier en ouvrant légèrement l'accroche à l'aide d'une pince.

3

- Si vous disposez d'une capote à commande électrique, retirez l'étrier en fil (1) situé entre la casquette et le premier arceau.

4

- Démonter les 2 écrous borgnes qui maintiennent l'équerre (C) derrière le joint de vitre arrière.
- Retirer la vis cruciforme qui maintient la bande élastique.
- Retirer partiellement le joint de la vitre arrière (B).
- Percer les rivets situés sous le joint de vitre arrière (B) et retirer le joint puis le rail (A).
- Décoller la toile de la capote sous le rail (A).

Vous aimerez aussi...



CAPOTES



WINDSCHOTTS



PORTE-BAGAGES



BAGAGERIES



SELLERIES



Comptoir du
Cabriolet



NOTICE DE MONTAGE

BMW E30
1985 - 1993

5

- Retirer le joint arrière (5).
- Retirer les 9 vis cruciformes situées sous le joint arrière et déposer le rail (4).
- Dégager la capote au niveau des arceaux intermédiaires.
- Couper la toile au niveau de la couture.
- Enlever la toile de l'arceau.

MONTAGE DE LA NOUVELLE CAPOTE

1

- Placer la capote sur l'armature avec les 2 poignées ouvertes.
- Placer provisoirement la capote au niveau de la casquette.
- Mettre en place la capote à l'arrière au niveau des côtés.
- Commencer par encoller et positionner le coin sur l'ergo métallique de l'armature (fig.1).

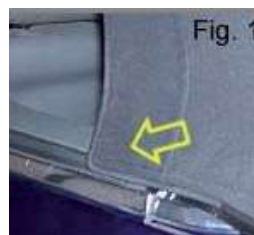

- Centrer et positionner la toile.
- Encoller et positionner les parties latérales.

Vous aimerez aussi...



CAPOTES



WINDSCHOTTS



PORTE-BAGAGES



BAGAGERIES



SELLERIES



Comptoir du
Cabriolet



NOTICE DE MONTAGE

BMW E30 1985 - 1993

2

- Encoller les 2 épaisseurs de tissus sur l'arrière du rail (4) et sous la structure.
- Encoller le tissu recouvrant la barre arrière.
- Vérifier le centrage de la partie arrière, l'extrémité de la toile doit pointer vers le bas.
- Remonter le rail porte-joint (4).

3

- Mettre en place les câbles latéraux.
- Mettre en place la partie avant de la capote.



- Encoller et replier la toile sur l'avant.

Vous aimerez aussi...



CAPOTES



WINDSCHOTTS



PORTE-BAGAGES



BAGAGERIES



SELLERIES



Comptoir du
Cabriolet



NOTICE DE MONTAGE

BMW E30 1985 - 1993

4

- Dès que la colle est sèche, fermer les poignées à l'avant et contrôler la tension de la capote.
- Ouvrir la capote et finir l'encollage latéral.
- Remonter le rail (A) sur la toile en réalisant un joint au silicone puis percer et riveter.
- Remonter le joint (B) dans le rail (A) et le fixer en partie basse.
- Percer la toile pour laisser passer les 2 vis de maintien de l'équerre (C) et remonter les écrous borgnes.
- Remonter la vis de maintien de la bande élastique (les capotes d'origine disposent d'un oeillet de fixation métallique, si votre capote n'en est pas équipée il vous suffit de doubler la toile et faire un trou à l'emporte-pièce).

5

- Remonter le rail avant (B1) avec les 5 vis cruciformes, en réalisant un joint silicone au préalable.
- Placer le nouveau joint avant en le collant au silicone sur 10cm à chaque extrémité.
- Mettre en place le joint au niveau des vitres latérales dans les glissières alu.
- Étancher proprement les 2 coins pour avoir une étanchéité parfaite à l'avant.

6

- Fermer la capote (la première fermeture est assez difficile).
- Encoller les bandes de tissu qui bloquent la capote sur les 4 arceaux intermédiaires.
- Vérifier la bonne fermeture des vitres et le placement des joints.
- Remonter le joint arrière (5).

Vous aimerez aussi...



CAPOTES



WINDSCHOTTS



PORTE-BAGAGES



BAGAGERIES



SELLERIES



NOTICE DE MONTAGE

Comptoir du
Cabriolet

BMW E30
1985 - 1993

Quelques conseils

- Travaillez dans un local aéré et avec une température ambiante d'environ 20°C.
- Après le montage, la capote doit rester tendue plusieurs jours.
- Ne pas laisser la capote repliée pendant une durée prolongée.
- Lors des premiers pliages, il faut veiller à bien accompagner la toile pendant toute l'opération et s'assurer qu'elle se plie correctement pour rentrer dans le coffre à capote.
- Nous conseillons de toujours placer un tissu ou une serviette de protection sur la lunette arrière pour éviter qu'elle ne s'abîme.

Vous aimerez aussi...



CAPOTES



WINDSCHOTTS



PORTE-BAGAGES



BAGAGERIES



SELLERIES



ATENCIÓN

INFORMACIÓN

1/ COMPRUEBE LA RECEPCIÓN EN UN PLAZO DE 48 HORAS:

- Asegúrese de que ha recibido el producto correcto. Coloca la capota sobre tu antigua capota y asegúrese de que el producto es del tamaño adecuado y tiene las mismas características que el como la capota existente.

Le recordamos que no se aceptará la devolución de ningún artículo con restos de pegamento o de instalación

- Despliegue la capota y deje que se relaje a una temperatura cercana a los 20°.
- Si la capota no tiene todos los accesorios que tiene la capota original, téngalo en cuenta a la hora de volver a montarla.

2 / COMPROBAR EL ESTADO DE LAS MANILLAS DE CIERRE :

- Compruebe que sus asas no están divididas:

Al montar la nueva capota, el tensado es siempre difícil y requiere mucha tracción en las manillas. Este tirón disminuirá muy rápidamente una vez que la capota esté colocada.

3/ CAPÓS ELÉCTRICOS :

ANTES DEL DESMONTAJE

- Compruebe que el sistema funciona correctamente, que el nivel de aceite es satisfactorio y que la batería está bien cargada.

ANTES DEL REMONTAJE (sin la parte superior)

- Compruebe el funcionamiento de la barra antivuelco.
- Limpie y lubrique todos los pasadores.
- Reemplace cualquier banda elástica suelta.
- Compruebe que los distintos aros se pliegan con normalidad en la caja de la capota cuando ésta se retira.
- Si es necesario, cambie todas las correas.

Si no respeta estos puntos, la barra antivuelco puede perforar el capó.

4/ PRODUCTOS NO DISPONIBLES EN STOCK o PEDIDOS ESPECIALES :

- Los pedidos especiales y los productos que no están en stock no se pueden devolver ni cambiar.
- Para los demás productos en stock, los gastos de devolución corren a su cargo, así como los gastos de inspección y reenvasado.
- El producto debe estar en condiciones nuevas, con las transparencias en el embalaje original.

También le gustará...



CAPOTAS



DEFLECTORES DE VIENTO



PORTAEQUIPAJES



EQUIPAJE A MEDIDA



GUARNICIONERIAS



CONSEJOS DE MANTENIMIENTO

COBERTURA

Acaba de adquirir un producto de calidad, cuyas cualidades apreciará, siempre que se mantenga con cuidado. Para ello, le recomendamos que siga las siguientes instrucciones:

Mantenga su barra antivuelco

Cuando se retire el capó antiguo, compruebe el funcionamiento y la lubricación de la barra antivuelco para evitar que se dañe el capó nuevo.

Cada tres meses compruebe el funcionamiento y la lubricación de su barra antivuelco con Degrippant.

Lavado de la capota

No lave la parte superior en una lavadora automática de rodillos.

Los capotas deben lavarse a la sombra, con agua fría.

Después de mojar bien la encimera, recomendamos rociar los limpiadores RENOVO (Ref DC01037 o DC01038) y cepillar la encimera con el cepillo suave.

Aclarar bien después.

Lave siempre toda la capota para evitar las manchas.

Mantenga el capó cerrado hasta que esté completamente seco.

No utilice limpiadores químicos que contengan acetona, alcohol metílico, gasolina en cualquiera de sus formas, diluyentes, desengrasantes o disolventes....

Utilizar sólo los productos que comercializamos y cuyos resultados y seguridad garantizamos.

Mantenimiento de la luneta trasera de cristal blando

Desbloquee la capota por delante, antes de manipular la cremallera.

No utilice limpiadores químicos que contengan acetona, alcohol metílico, gasolina en cualquiera de sus formas, diluyentes, desengrasantes o disolventes.

No manipule su carenado cuando la temperatura sea inferior a 10°. Se corre el riesgo de romper la ventanilla trasera blanda.

Si el mecanismo es eléctrico, le aconsejamos que compruebe a mitad de recorrido que la luneta trasera blanda se pliega correctamente.

Lavar la ventana con agua limpia utilizando las fundas de pulido.

Limpie y elimine las micro rayas, utilizando las fundas de pulido para aplicar el renovador de vidrio suave en ambas caras.

Manipulación del capota

Antes de plegar la capota en el maletero, compruebe que está limpia y seca. Esto evitará el encogimiento, las manchas de humedad y los arañazos en la luna trasera blanda.

Impermeabilización, renovación, repintado

Utilizar sólo los productos que vendemos y que han sido probados.

En el reverso de este documento encontrará los Kits que contienen todos los productos detallados en nuestro catálogo.

También le gustará...



CAPOTAS



DEFLECTORES DE VIENTO



PORTAEQUIPAJES



EQUIPAJE A MEDIDA



GUARNICIONERIAS



PREPARACIÓN INSTALACIÓN INSTALACIÓN DE UNA CAPOTA

1/ COMPRUEBA LA RECEPCIÓN:

Asegúrese de que ha recibido el producto correcto:

Presente el toldo sobre su antiguo toldo y asegúrese de que el producto es del tamaño adecuado y con las mismas características que el toldo existente.

LE RECORDAMOS QUE NO SE ACEPTARÁ LA DEVOLUCIÓN DE NINGÚN ARTÍCULO CON RESTOS DE PEGAMENTO O DE INSTALACIÓN.

2 / PREPARACIÓN DE LAS HERRAMIENTAS :

Remachadora y remaches variados.

Pegamento de neopreno y pincel.

Cinta métrica y tiza.

Un martillo y una cuña de madera.

Cortador de hoja grande y pequeña.

Alicates universales

Llave plana: 8/10/11/12/13.

Llave de tubo: 8/10/11/12/13.

Destornilladores planos y de estrella.

3 / COMPROBAR EL ESTADO DE LAS MANILLAS DE CIERRE :

Compruebe que sus asas no están divididas:

Al montar la nueva capota, el tensado es siempre difícil y requiere mucha tracción en las manillas. Este tirón disminuirá muy rápidamente una vez que la capota esté colocada.

4 / INSTALACIÓN DE CAPOTAS EN PVC :

Los capotas de PVC deben instalarse en un entorno cálido para que sean flexibles durante la instalación.

En verano, basta con dejarlo al sol.

En invierno, debe calentarse con una pistola de calor (a una distancia mínima de 20 cm. A menos que pueda utilizar una cabina de pintura).

PRIMER CIERRE DEL TECHO DE PVC: Será difícil, pueden ser necesarias dos personas para cerrar el techo. Esto es normal. Al día siguiente habrá ocupado su lugar y la maniobra de apertura o cierre se realizará sin problemas.

5 / VENTANA TRASERA BLANDA

Si hay pliegues en la transparencia blanda, puede eliminarlos de la siguiente manera:

Con un secador de pelo colocado a una distancia mínima de 25 cm, calienta la parte que tiene un pliegue con un movimiento circular.

En cuanto el bisel se ablande, deje de calentar;

Deje que el bisel se enfríe mientras tira de la tela que bordea el bisel para apretarlo, y retire el pliegue.

También le gustará...



CAPOTAS



DEFLECTORES DE
VIENTO



PORTAEQUIPAJES



EQUIPAJE
A MEDIDA



GUARNICIONERIAS



MANUAL DE MONTAJE

BMW E30 1985 - 1993

ADVERTENCIA IMPORTANTE:

- Éximo todo el documento antes de iniciar el montaje
- Como este documento fue producido para profesionales experimentados, algunos pasos de ensamblaje no se describen
- La garantía no cubrirá los daños causados por una instalación incorrecta
- **Se recomienda encarecidamente la instalación por parte de un profesional**
- Al desmontar, mantenga cuidadosamente todas las piezas y anote su posición original, serán Esencial al lugar la nueva capota blanda
- Inspeccione la capota blanda antes de colocarla, si hay alguna imperfección en el material, póngase en contacto con su servicio de atención al cliente, **su Capucha mezclar no será devuelta ni cambiada después de la instalación.**
- **Antes de encajar, Poner las 2 tapas una encima de la otra para comprobar que las dimensiones y los perfiles coincidan perfectamente,** Sí hay una diferencia, comuníquese con su servicio de atención al cliente.

ES IMPRESCINDIBLE QUE CAMBIE LAS CORREAS CUANDO SUSTITUYA LAS CAPOTAS.

Las correas usadas no permiten guardar la capota en el cofre de la capota. Existe el riesgo de que la tela de la capota sea perforada por el aro.

Herramientas necesarias

- Destornillador
- Taladro
- Pistola de remaches
- Llave de tubo de 7 pulgadas
- Cortador

También le gustará...



CAPOTAS



DEFLECTORES DE
VIENTO



PORTAEQUIPAJES



EQUIPAJE
A MEDIDA



GUARNICIONERIAS



Comptoir du
Cabriolet

MANUAL DE MONTAJE

BMW E30 1985 - 1993

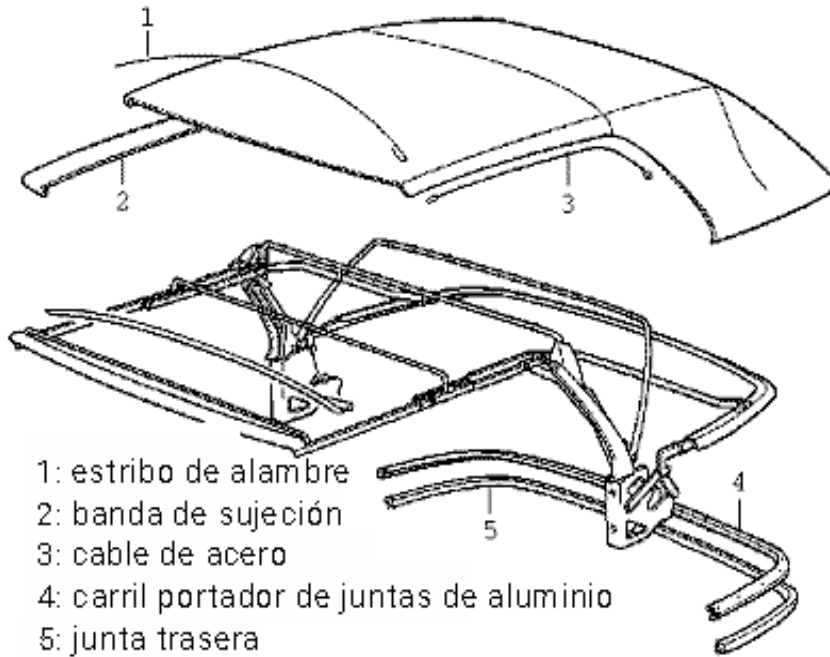

B1: barandilla delantera (ref 54311932704)

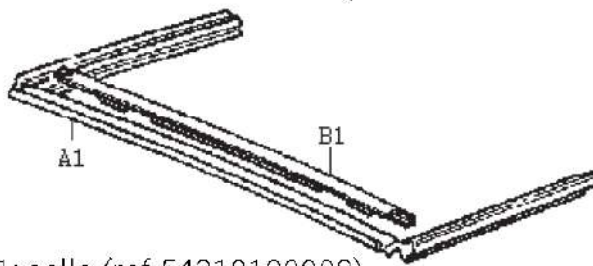

A1: sello (ref 54318100908)

A: ferrocarril
B: sello
C: soporte



También le gustará...



CAPOTAS



DEFLECTORES DE
VIENTO



PORTAEQUIPAJES



EQUIPAJE
A MEDIDA



GUARNICIONERIAS



**Comptoir du
Cabriolet**



MANUAL DE MONTAJE

BMW E30 1985 - 1993

1

- Retire la junta de cierre frontal (en forma de U) (A1) tirando primero de ella para sacarla de los raíles situados por encima de las ventanas laterales.
- Continúe con la parte delantera de la tapa (utilice un cúter si es necesario para cortar el sellador que sujeta la junta en el carril de aluminio (B1)).
- Retire los 5 tornillos de estrella situados debajo de la junta.
- Retire el riel (B1).
- Retire la capota de la tapa.

2

- Retire los cables laterales por encima del borde.
- Desenganche los cables de acero abriendo ligeramente el gancho con unos alicates.

3

- Si tiene una capota eléctrica, retire el soporte de cables (1) situado entre la tapa y la primera barra anti-vuelco.

4

- Retire las 2 tuercas de sombrerete que sujetan el soporte (C) detrás de la junta de la ventana trasera.
- Retire el tornillo Phillips que sujeta la banda elástica.
- Retire parcialmente la junta de la luneta trasera (B).
- Taladre los remaches situados debajo de la junta de la luneta trasera (B) y retire la junta y, a continuación, el riel (A).
- Retire la tela de la capota debajo del riel (A).

También le gustará...



CAPOTAS



**DEFLECTORES DE
VIENTO**



PORTAEQUIPAJES



**EQUIPAJE
A MEDIDA**



GUARNICIONERIAS



Comptoir du
Cabriolet



MANUAL DE MONTAJE

BMW E30 1985 - 1993

5

- Retire la junta trasera (5).
- Retire los 9 tornillos Phillips situados debajo de la junta trasera y retire el riel (4).
- Retire la capota por los aros intermedios.
- Corte la tela en la costura.
- Retire la tela de la barra antivuelco.

MONTAJE DE LA NUEVA CAPOTA

1

- Coloque la capota en el bastidor con las dos asas abiertas.
- Coloque la capota provisionalmente en la tapa.
- Coloque la capota en la parte trasera.
- Primero pegue y coloque la esquina en el pasador metálico del marco (fig.1).

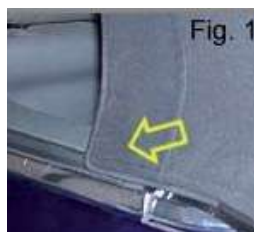

- Centrar y colocar la tela.
- Pegue y coloque los laterales.

También le gustará...



CAPOTAS



DEFLECTORES DE
VIENTO



PORTAEQUIPAJES



EQUIPAJE
A MEDIDA



GUARNICIONERIAS



Comptoir du
Cabriolet



MANUAL DE MONTAJE

BMW E30 1985 - 1993

2

- Pegue las 2 capas de tela en la parte posterior de la barra (4) y debajo de la estructura.
- Pegue la tela que cubre la barra trasera.
- Compruebe que la parte trasera está centrada, el extremo de la tela debe apuntar hacia abajo.
- Vuelva a colocar la barra de unión (4).

3

- Colocar los cables laterales.
- Montar la parte delantera de la capota.



- Pegue y doble la tela en la parte delantera.

También le gustará...



CAPOTAS



DEFLECTORES DE
VIENTO



PORTAEQUIPAJES



EQUIPAJE
A MEDIDA



GUARNICIONERIAS



Comptoir du
Cabriolet



MANUAL DE MONTAJE

BMW E30 1985 - 1993

4

- En cuanto se haya secado el pegamento, cierre las asas de la parte delantera y compruebe la tensión de la capota.
- Abra la capota y termine el encolado lateral.
- Vuelva a colocar el riel (A) en la tela haciendo un sello de silicona, luego perfora y remache.
- Vuelva a colocar la junta (B) en el riel (A) y fíjela en la parte inferior.
- Taladre agujeros en la tela para que pasen los 2 tornillos que sujetan el soporte (C) y coloque las tuercas ciegas.
- Vuelva a colocar el tornillo que sujeta la banda elástica (las capotas originales tienen un ojal metálico, si su capota no está equipada con uno, basta con doblar la tela y hacer un agujero con un punzón).

5

- Vuelva a colocar el carril delantero (B1) con los 5 tornillos de estrella, haciendo previamente una junta de silicona.
- Coloque la nueva junta frontal pegándola con silicona a lo largo de 10 cm en cada extremo.
- Coloque la junta en las ventanas laterales en las guías de aluminio.
- Sellar las dos esquinas para asegurar un perfecto sellado en la parte delantera.

6

- Cerrar la capota (el primer cierre es bastante difícil).
- Pegue las tiras de tela que fijan la capota a los 4 aros intermedios.
- Compruebe que las ventanillas cierran correctamente y que las juntas están en su sitio.
- Vuelva a colocar la junta trasera (5).

También le gustará...



CAPOTAS



DEFLECTORES DE
VIENTO



PORTAEQUIPAJES



EQUIPAJE
A MEDIDA



GUARNICIONERIAS



Comptoir du
Cabriolet



MANUAL DE MONTAJE

BMW E30
1985 - 1993

Algunos consejos

- Trabaje en una habitación ventilada con una temperatura ambiente de unos 20°C.
- Después de la instalación, la capota debe dejarse tensa durante varios días.
- No deje la capota plegada durante mucho tiempo.
- Al plegar la capota por primera vez, asegúrese de acompañar la tela durante todo el proceso y de que se pliegue correctamente para que quepa en el cofre de la capota.
- Le recomendamos que coloque siempre un paño o toalla de protección sobre la luneta trasera para evitar que se dañe.

También le gustará...



CAPOTAS



DEFLECTORES DE
VIENTO



PORTAEQUIPAJES



EQUIPAJE
A MEDIDA



GUARNICIONERIAS



WARNING INFORMATION

1/ CHECK THE RECEPTION WITHIN 48 HOURS:

- Make sure you have received the correct product. Place the soft top over your old one and make sure the product is the right size and has the same features as the existing soft top.

We remind you that no item with traces of glue or traces of installation will be taken back

- Unfold the soft top and allow it to relax in a temperature close to 20°.
- If the soft top does not have all the accessories that the original soft top has, take this into account when reassembling.

2 / CHECK THE CONDITION OF THE CLOSING HANDLES :

- Check that your handles are not split:

When fitting the new soft top, tensioning is always difficult and requires a lot of traction on the handles. This tension will decrease very quickly once the soft top is in place.

3/ ELECTRIC SOFT TOPS :

BEFORE DISASSEMBLY

- Check that the system works perfectly, that the oil level is satisfactory and that the battery is well charged.

BEFORE REASSEMBLY (soft top removed)

- Check the operation of the roll bar.
- Clean and lubricate all pins.
- Replace any loose elastic bands.
- Check that the various hoops fold normally in the soft top box when the top is removed.
- If necessary, change all straps.

If you do not follow these points, the roll bar may puncture the soft top.

4/ PRODUCTS NOT HELD IN STOCK or SPECIAL ORDER :

- Special orders and products not held in stock cannot be returned or exchanged.
- For other products in stock, the cost of return is at your expense, as well as the cost of inspection and repackaging.
- The product must be in new condition with the transparencies in the original packaging.

You will also like...



SOFT TOPS



WIND DEFLECTORS



LUGGAGE RACKS



TAILOR-MADE
LUGGAGES



SADDLERIES



MAINTENANCE ADVICE

COVERING

You have just acquired a quality product, the qualities of which you will appreciate, provided that it is carefully maintained.

To do this, we recommend that you observe the following instructions:

Maintain your roll bar

When the old soft top is removed, check the operation and lubrication of the roll bar to avoid damaging the new soft top.

Every three months check the operation and lubrication of your roll bar using Degrippant.

Washing your soft top

Do not wash the tops in an automatic roller wash.

The soft tops should be washed in the shade, using cold water.

After wetting the top thoroughly, we recommend spraying the RENOVO cleaners (Ref DC01037 or DC01038) and brushing the top with the soft brush.

Rinse well afterwards.

Always wash the entire soft top to avoid stains.

Keep the bonnet closed until it is completely dry.

Do not use chemical cleaners containing acetone, methylated spirits, petrol in any form, thinners, degreasers or solvents....

Only use products that we market and whose results and safety we guarantee.

Maintenance of the soft crystal rear window

Unlock the soft top at the front, before handling the zip.

Do not use chemical cleaners containing acetone, methylated spirits, petrol in any form, thinners, degreasers or solvents.

Do not handle your cowling when the temperature is below 10°. You risk cracking the soft rear window.

If the mechanism is electric, we advise you to check halfway through the ride that the soft rear window folds correctly.

Wash the window with clear water using the polishing sleeves.

Clean and remove micro-scratches, using the polishing sleeves to apply the soft glass renovator on both sides.

Handling your soft top

Before folding your soft top into the boot, check that it is clean and dry. This will prevent shrinkage, moisture stains and scratches on the soft rear window.

Waterproofing, renovation, recolouring

Only use products that we sell and that have proven themselves.

You will find on the back of this document, the Kits which contain all the products detailed in our catalogue.

You will also like...



SOFT TOPS



WIND DEFLECTORS



LUGGAGE RACKS



TAILOR-MADE
LUGGAGES



SADDLERIES



PREPARATION INSTALLATION

INSTALLATION OF A SOFT TOP

1/ CHECK THE RECEPTION:

Make sure you have received the correct product:

Present the soft top over your old soft top and make sure the product is the right size and with the same features as the existing soft top.

WE REMIND YOU THAT NO ARTICLE WITH TRACES OF GLUE OR TRACES OF INSTALLATION WILL BE TAKEN BACK.

2 / TOOLING PREPARATION :

Riveter and assorted rivets.

Neoprene glue and brush.

Tape measure and chalk.

A hammer and a wooden wedge.

Large and small blade cutter.

Universal pliers

Flat spanner: 8/10/11/12/13.

Pipe spanner: 8/10/11/12/13.

Flat and crosshead screwdrivers.

3 / CHECK THE CONDITION OF THE CLOSING HANDLES :

Check that your handles are not split:

When fitting the new soft top, tensioning is always difficult and requires a lot of traction on the handles. This tension will decrease very quickly once the soft top is in place.

4 / INSTALLATION OF PVC TOPS :

PVC tops should be installed in a warm environment so that they are flexible during installation.

In summer, it is sufficient to leave it in the sun. In winter, it should be heated with a heat gun (minimum distance 20cm. Unless you can use a paint booth).

FIRST CLOSING OF THE PVC top: It will be difficult, it may take two people to close the soft top.

This is normal. The next day it will have taken its place and the opening or closing manoeuvre will be carried out without problem.

5 / SOFT REAR WINDOW

If there are any folds on the soft transparency, you can remove them as follows:

With a hair dryer placed at least 25 cm away, heat the part that has a fold in a circular motion.

As soon as the bezel becomes soft, stop heating;

Let the bezel cool down while pulling on the fabric that borders the soft bezel in order to tighten the soft bezel, and erase the fold.

You will also like...



SOFT TOPS



WIND DEFLECTORS



LUGGAGE RACKS



**TAILOR-MADE
LUGGAGES**



SADDLERIES



Comptoir du
Cabriolet



ASSEMBLY MANUAL

BMW E30
1985 - 1993

IMPORTANT WARNING:

- Read the whole document before starting the assembly.
- As this document was produced for experienced professionals, some assembly steps are not described.
- The warranty will not cover damage caused by incorrect installation.
- **Installation by a professional is strongly recommended.**
- When disassembling, carefully keep all the parts and note their original position, they will be indispensable when fitting the new soft top.
- Inspect the soft top before fitting, if there are any imperfections in the material contact your customer service, your soft top will not be returned or exchanged after fitting
- **Before fitting, place the 2 tops on top of each other to check that the dimensions and profiles match perfectly**, if there is a difference contact your customer service.

IT IS IMPERATIVE THAT YOU CHANGE THE STRAPS WHEN REPLACING THE SOFT TOPS.

The used straps do not allow the soft top to be stored in the soft top box. There is a risk that the soft top fabric will be punctured by the hoop.

Tools required

- Screwdriver
- Drill
- Rivet gun
- 7» pipe spanner
- Cutter

You will also like...



SOFT TOPS



WIND DEFLECTORS



LUGGAGE RACKS



TAILOR-MADE
LUGGAGES



SADDLERIES



ASSEMBLY MANUAL

Comptoir du
Cabriolet

BMW E30
1985 - 1993

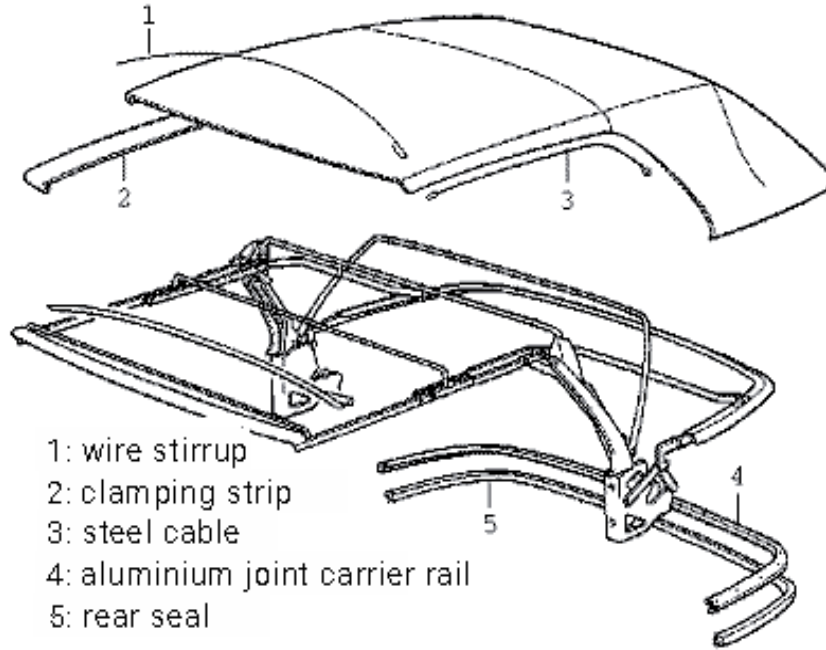

B1: front rail (ref 54311932704)

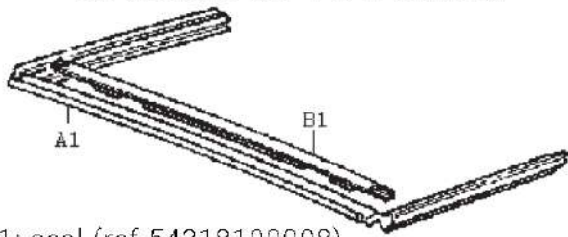

A1: seal (ref 54318100908)

A: rail
B: seal
C: bracket

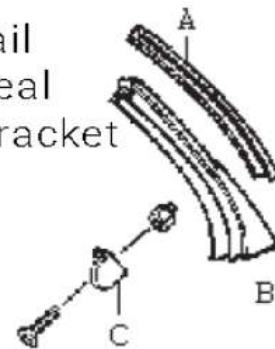

You will also like...



SOFT TOPS



WIND DEFLECTORS



LUGGAGE RACKS



TAILOR-MADE
LUGGAGES



SADDLERIES



Comptoir du
Cabriolet



ASSEMBLY MANUAL

BMW E30
1985 - 1993

1

- Remove the front closure (U-shaped) seal (A1) by first pulling it out of the rails above the side windows.
- Continue with the front of the cap (use a cutter if necessary to cut the sealant holding the gasket in the aluminium rail (B1)).
- Remove the 5 crosshead screws under the seal.
- Remove the rail (B1).
- Remove the soft top from the cap.

2

- Remove the side cables above the edge.
- Unhook the steel cables by slightly opening the hook with pliers.

3

- If you have a power soft top, remove the wire bracket (1) located between the cap and the first roll bar.

4

- Remove the 2 cap nuts that hold the bracket (C) behind the rear window seal.
- Remove the Phillips screw holding the elastic band.
- Partially remove the rear window seal (B).
- Drill out the rivets under the rear window seal (B) and remove the seal and then the rail (A).
- Peel off the soft top fabric under the rail (A).

You will also like...



SOFT TOPS



WIND DEFLECTORS



LUGGAGE RACKS



**TAILOR-MADE
LUGGAGES**



SADDLERIES



Comptoir du
Cabriolet



ASSEMBLY MANUAL

BMW E30
1985 - 1993

5

- Remove the rear seal (5).
- Remove the 9 Phillips screws under the rear seal and remove the rail (4).
- Remove the soft top at the intermediate hoops.
- Cut the fabric at the seam.
- Remove the fabric from the roll bar.

FITTING THE NEW SOFT TOP

1

- Place the soft top on the frame with both handles open.
- Place the soft top provisionally on the cap.
- Position the soft top at the rear side.
- First glue and position the corner on the metal pin of the frame (fig.1).

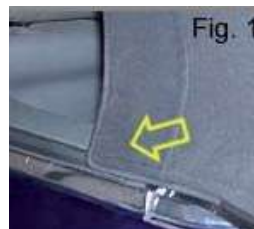

- Centre and position the canvas.
- Glue and position the sides.

You will also like...



SOFT TOPS



WIND DEFLECTORS



LUGGAGE RACKS



TAILOR-MADE
LUGGAGES



SADDLERIES



ASSEMBLY MANUAL

Comptoir du
Cabriolet

BMW E30
1985 - 1993

2

- Glue the 2 layers of fabric on the back of the rail (4) and under the structure.
- Glue the fabric covering the rear bar.
- Check that the rear section is centred, the end of the fabric must point downwards.
- Refit the joint rail (4).

3

- Fit the side cables.
- Fit the front part of the soft top.



- Glue and fold the fabric to the front.

You will also like...



SOFT TOPS



WIND DEFLECTORS



LUGGAGE RACKS



TAILOR-MADE
LUGGAGES



SADDLERIES



**Comptoir du
Cabriolet**



ASSEMBLY MANUAL

**BMW E30
1985 - 1993**

4

- As soon as the glue has dried, close the handles at the front and check the tension of the soft top.
- Open the soft top and finish the side gluing.
- Refit the rail (A) to the fabric by making a silicone seal, then drill and rivet.
- Refit the seal (B) in the rail (A) and fix it at the bottom.
- Drill holes in the fabric to allow the 2 screws holding the bracket (C) to pass through and fit the cap nuts.
- Refit the screw holding the elastic band (the original soft tops have a metal eyelet, if your soft top is not equipped with one, you just need to double the fabric and make a hole with a punch).

5

- Refit the front rail (B1) with the 5 crosshead screws, making a silicone seal beforehand.
- Place the new front seal by gluing it with silicone over 10cm at each end.
- Place the seal at the side windows in the aluminium guides.
- Seal the two corners to ensure a perfect seal at the front.

6

- Close the soft top (the first closing is rather difficult).
- Glue the fabric strips that secure the soft top to the 4 intermediate hoops.
- Check that the windows close properly and that the seals are in place.
- Refit the rear seal (5).

You will also like...



SOFT TOPS



WIND DEFLECTORS



LUGGAGE RACKS



**TAILOR-MADE
LUGGAGES**



SADDLIERIES



Comptoir du
Cabriolet



ASSEMBLY MANUAL

BMW E30
1985 - 1993

A few tips

- Work in a ventilated room with an ambient temperature of about 20°C.
- After installation, the soft top should be left taut for several days.
- Do not leave the soft top folded for a long time.
- When folding the soft top for the first time, make sure that you accompany the fabric during the entire process and that it folds correctly to fit into the soft top box.
- We recommend that you always place a protective cloth or towel over the rear window to prevent it from being damaged.

You will also like...



SOFT TOPS



WIND DEFLECTORS



LUGGAGE RACKS



**TAILOR-MADE
LUGGAGES**



SADDLERIES



ADVERTÊNCIA

INFORMAÇÃO

1/ VERIFICAR A RECEPÇÃO NO PRAZO DE 48 HORAS:

- Certifique-se de ter recebido o produto correcto. Coloque a capota sobre a sua antiga e certifique-se de que o produto tem o tamanho certo e as mesmas características que a capota existente.

Recordamos que nenhum artigo com vestígios de cola ou vestígios de instalação será recuperado

- Desdobre a capota e deixe-a relaxar a uma temperatura próxima dos 20°.
- Se a capota não tiver todos os acessórios que a capota original tem, ter isto em conta ao montar de novo.

2 / VERIFICAR O ESTADO DAS PEGAS DE FECHO :

- Verifique se as suas pegas não estão divididas:

Ao montar a nova capota, a tensão é sempre difícil e requer muita tracção nas pegas. Esta tensão diminuirá muito rapidamente assim que a capota estiver no lugar.

3/ SOFT TOPS ELÉCTRICOS :

ANTES DA DESMONTAGEM

- Verificar se o sistema funciona perfeitamente, se o nível de óleo é satisfatório e se a bateria está bem carregada.

ANTES DE REASSEMBLEAR (capote removido)

- Verificar o funcionamento da barra de rolagem.
- Limpar e lubrificar todos os pinos.
- Substituir quaisquer bandas elásticas soltas.
- Verificar se os vários arcos dobram normalmente na caixa da capota quando a capota é removida.
- Se necessário, trocar todas as cintas.

Se não seguir estes pontos, a barra de rolagem pode perfurar a parte superior macia.

4/ PRODUTOS NÃO ACOMPANHADOS EM PEDIDO ESPECIAL ou STOCK :

- Encomendas e produtos especiais não mantidos em stock não podem ser devolvidos ou trocados.
- Para outros produtos em stock, o custo da devolução é por sua conta, assim como o custo da inspecção e reembalagem.
- O produto deve estar em novas condições com as transparências na embalagem original.

Também vai gostar...



CAPOTAS MACIOS



DEFLETORES DE VIENTO



PORTA-BAGAGENS



BAGAGENS A MEDIDA



ESTOFAMENTO



CONSELHOS DE MANUTENÇÃO

ABRANGENDO

Acaba de adquirir um produto de qualidade, cujas qualidades irá apreciar, desde que seja cuidadosamente mantido.

Para tal, recomendamos-lhe que observe as seguintes instruções:

Mantenha a sua barra de rolagem

Quando a capota velha é removida, verificar o funcionamento e lubrificação da barra de rolagem para evitar danificar a nova capota.

De três em três meses, verifique o funcionamento e lubrificação da sua barra de rolagem usando a Degrippant.

Lavar a sua capota

Não lavar as tampas numa lavagem automática com rolos.

As tampas macias devem ser lavadas à sombra, utilizando água fria.

Depois de molhar bem a parte superior, recomendamos a pulverização dos produtos de limpeza RENOVO (Ref. DC01037 ou DC01038) e a escovagem da parte superior com a escova macia.

Enxaguar bem depois.

Lavar sempre toda a parte superior macia para evitar manchas.

Manter a capota fechada até estar completamente seca.

Não utilizar produtos de limpeza químicos que contenham acetona, álcool desnaturado, gasolina sob qualquer forma, diluentes, desengordurantes ou solventes...

Utilizar apenas produtos que comercializamos e cujos resultados e segurança garantimos.

Manutenção do vidro traseiro de cristal macio

Desbloquear a capota na frente, antes de manusear o fecho.

Não utilizar produtos de limpeza químicos que contenham acetona, álcool desnaturado, gasolina sob qualquer forma, diluentes, desengordurantes ou solventes.

Não manusear a sua capota quando a temperatura for inferior a 10°. Arrisca-se a rachar o vidro traseiro macio.

Se o mecanismo for eléctrico, aconselhamo-lo a verificar a meio da viagem que o que a janela traseira macia se dobra correctamente.

Lavar a janela com água limpa utilizando as mangas de polimento.

Limpar e remover micro-riscas, utilizando as mangas de polimento para aplicar o vidro macio renovador em ambos os lados.

Manuseamento da sua capota

Antes de dobrar a sua capota para dentro da bota, verifique se está limpa e seca. Isto evitará o encolhimento, manchas de humidade e arranhões no vidro traseiro macio.

Impermeabilização, renovação, recolha de recordações

Utilizar apenas produtos que vendemos e que já provaram a sua eficácia.

Encontrará no verso deste documento, os Kits que contêm todos os produtos detalhados no nosso catálogo.

Também vai gostar...



CAPOTAS MACIOS



DEFLETORES DE VIENTO



PORTA-BAGAGENS



BAGAGENS A MEDIDA



ESTOFAMENTO



INSTALAÇÃO DE PREPARAÇÃO INSTALAÇÃO DE UMA CAPOTA

1 / VERIFICAR A RECEPÇÃO:

Certifique-se de ter recebido o produto correcto:

Apresente a capota sobre a sua antiga capota e certifique-se de que o produto tem o tamanho certo e as mesmas características que a capota existente.

LEMBRAMOS QUE NENHUM ARTIGO COM VESTÍGIOS DE COLA OU VESTÍGIOS DE INSTALAÇÃO SERÁ RETOMADO.

2 / PREPARAÇÃO DE FERRAMENTAS :

Rebitador e rebites variados.

Cola e pincel de neoprene.

Fita métrica e giz.

Um martelo e uma cunha de madeira.

Cortador de lâminas grandes e pequenas.

Alicate universal

Chave de fenda plana: 8/10/11/12/13.

Chave de tubos: 8/10/11/12/13.

Chaves de fendas planas e transversais.

3 / VERIFICAR O ESTADO DAS PEGAS DE FECHO :

Verifique se as suas pegas não estão divididas:

Ao montar a nova capota, a tensão é sempre difícil e requer muita tracção nas pegas. Esta tensão diminuirá muito rapidamente assim que a capota estiver no lugar.

4 / INSTALAÇÃO DE TAMPOS DE PVC :

As tampas de PVC devem ser instaladas num ambiente quente, de modo a serem flexíveis durante a instalação.

No Verão, é suficiente deixá-los ao sol. No Inverno, deve ser aquecida com uma pistola de calor (distância mínima de 20cm. A menos que se possa usar uma cabina de pintura).

PRIMEIRO FECHAMENTO DO PISCÍPIO DE PVC: Será difícil, pode ser preciso duas pessoas para fechar a capota. Isto é normal. No dia seguinte terá tomado o seu lugar e a manobra de abertura ou fecho será efectuada sem problemas.

5 / JANELA TRASEIRA MACIA

Se houver dobras na transparência suave, pode removê-las como se segue:

Com um secador de cabelo colocado a pelo menos 25 cm de distância, aqueça a parte que tem uma dobra num movimento circular.

Assim que a luneta se tornar macia, parar o aquecimento;

Deixe a luneta arrefecer enquanto puxa o tecido que contorna a luneta macia, a fim de apertar a luneta macia, e apague a dobra.

Também vai gostar...



CAPOTAS MACIOS



DEFLETORES DE VIENTO



PORTA-BAGAGENS



BAGAGENS A MEDIDA



ESTOFAMENTO



MANUAL DE MONTAGEM

BMW E30 1985 - 1993

AVISO IMPORTANTE:

- Ler todos todos ou documento antes para começar um montagem
- Como este documento Foi Produzido para profissionais experientes, alguns passos de montagem não são descritos
- A garantia Não cobre danos Causado por uma instalação Incorreto
- **A instalação por em profissional é fortemente Recomendado**
- Ao desmontar, mantenha cuidadosamente todas as partes e note a sua posição original, serão Indispensável Para caber ou Novo Início suave
- Inspeccione a parte superior macia antes de ser montada, se houver alguma imperfeição no material contato ou o seu serviço para o cliente, **o seu Início suave Não será devolvido ou trocado após montagem**
- **Antes para se encaixar, Colocar como 2 Capas em até um dos Outros para verificar se as dimensões e Perfis Combinar perfeitamente si mesma Ali**, há Um diferença entrar em contato com o seu serviço ao cliente

É IMPERATIVO QUE SE TROQUEM AS CORREIAS AO SUBSTITUIR OS SOFT TOPS.

As cintas utilizadas não permitem que a capota seja armazenada na caixa da capota. Existe o risco de o tecido da capota ser perfurado pelo aro.

Ferramentas necessárias

- Chave de fendas
- Broca
- Rebitador
- Chave de canalização de 7».
- Cortador

Também vai gostar...



CAPOTAS MACIOS



DEFLETORES DE VIENTO



PORTA-BAGAGENS



BAGAGENS A MEDIDA



ESTOFAMENTO



Comptoir du
Cabriolet



MANUAL DE MONTAGEM

BMW E30 1985 - 1993

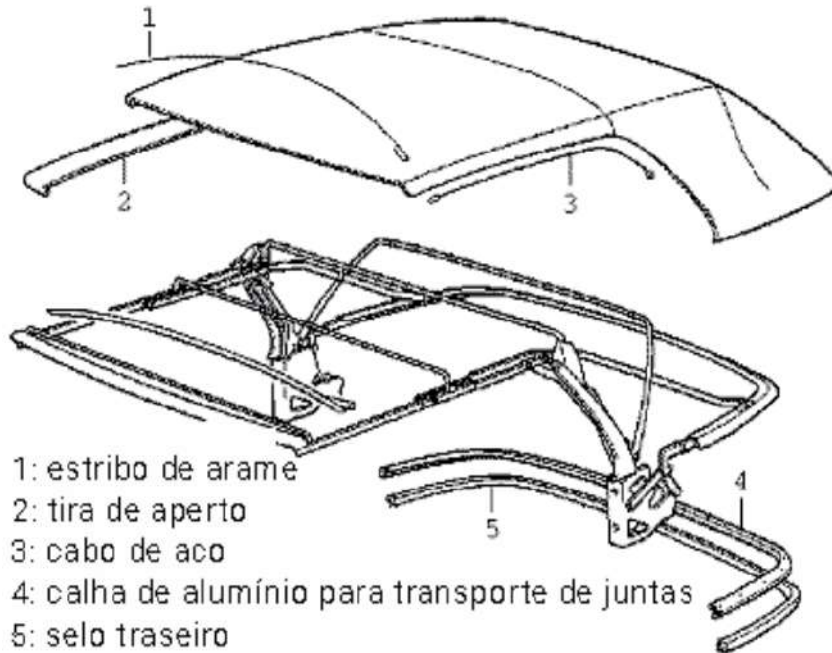

B1: trilho da frente (ref 54311932704)

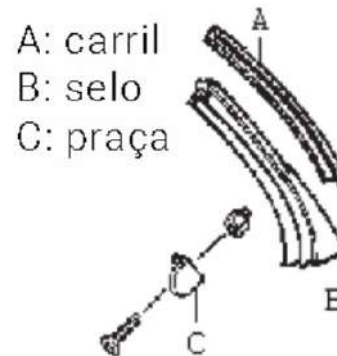
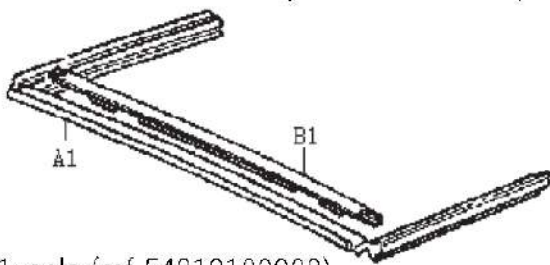

Também vai gostar...



CAPOTAS MACIOS



DEFLETORES DE
VIENTO



PORTA-BAGAGENS



BAGAGENS A MEDIDA



ESTOFAMENTO



**Comptoir du
Cabriolet**



MANUAL DE MONTAGEM

BMW E30 1985 - 1993

1

- Remover o fecho frontal (em U) de vedação (A1) puxando-o primeiro para fora dos carris por cima das janelas laterais.
- Continuar com a frente da tampa (utilizar um cortador se necessário para cortar o vedante que segura a junta na calha de alumínio (B1)).
- Retirar os 5 parafusos de cabeça cilíndrica por baixo do vedante.
- Retirar a calha (B1).
- Remover a parte superior macia da tampa.

2

- Retirar os cabos laterais acima da borda.
- Desenroscar os cabos de aço abrindo ligeiramente o gancho com um alicate.

3

- Se tiver um softtop de potência, remover o suporte de arame (1) localizado entre a tampa e a primeira barra de rolagem.

4

- Remover as 2 porcas de tampa que seguram o suporte (C) atrás do fecho da janela traseira.
- Remover o parafuso Phillips que segura a faixa elástica.
- Remover parcialmente a vedação do vidro traseiro (B).
- Perfurar os rebites sob a vedação da janela traseira (B) e remover a vedação e depois a calha (A).
- Descascar o tecido da parte superior macia por baixo da calha (A).

Também vai gostar...



CAPOTAS MACIOS



**DEFLETORES DE
VIENTO**



PORTA-BAGAGENS



BAGAGENS A MEDIDA



ESTOFAMENTO



**Comptoir du
Cabriolet**



MANUAL DE MONTAGEM

BMW E30
1985 - 1993

5

- Remover o selo traseiro (5).
- Remover os 9 parafusos Phillips por baixo do selo traseiro e remover a calha (4).
- Remover a parte superior macia nos arcos intermédios.
- Cortar o tecido na costura.
- Remover o tecido da barra de enrolar.

ENCAIXANDO O NOVO SOFT TOP

1

- Colocar a capota na moldura com ambas as pegas abertas.
- Colocar a capota provisoriamente sobre a tampa.
- Posicionar a capota na parte de trás.
- Colar primeiro e posicionar o canto no pino metálico da armação (fig.1).

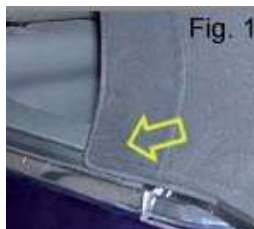

- Centrar e posicionar a tela.
- Colar e posicionar os lados.

Também vai gostar...



CAPOTAS MACIOS



DEFLETORES DE
VIENTO



PORTA-BAGAGENS



BAGAGENS A MEDIDA



ESTOFAMENTO



**Comptoir du
Cabriolet**



MANUAL DE MONTAGEM

BMW E30

1985 - 1993

2

- Colar as 2 camadas de tecido na parte de trás do carril (4) e por baixo da estrutura.
- Colar o tecido que cobre a barra traseira.
- Verificar se a secção traseira está centrada, a extremidade do tecido deve apontar para baixo.
- Voltar a montar a calha comum (4).

3

- Colocar os cabos laterais.
- Encaixar a parte da frente da capota.



- Colar e dobrar o tecido para a frente.

Também vai gostar...



CAPOTAS MACIOS



**DEFLETORES DE
VIENTO**



PORTA-BAGAGENS



BAGAGENS A MEDIDA



ESTOFAMENTO



**Comptoir du
Cabriolet**



MANUAL DE MONTAGEM

BMW E30 1985 - 1993

4

- Assim que a cola tiver secado, fechar as pegas à frente e verificar a tensão da capota.
- Abrir a capota e finish a colagem lateral.
- Recoloque a calha (A) no tecido, fazendo um selo de silicone, depois fure e rebite.
- Volte a colocar o selo (B) na calha (A) e fix na parte inferior.
- Fazer furos no tecido para permitir a passagem dos 2 parafusos que seguram o suporte (C) e encaixar as porcas da tampa.
- Volte a montar o parafuso que segura a faixa elástica (as capas macias originais têm um ilhós metálico, se a sua capota não estiver equipada com um, basta duplicar o tecido e fazer um furo com um soco).

5

- Voltar a montar o carril dianteiro (B1) com os 5 parafusos de cabeça cilíndrica, fazendo um selo de silicone de antemão.
- Colar o novo selo frontal colando-o com silicone com mais de 10cm em cada extremidade.
- Colocar o selo nas janelas laterais nas guias de alumínio.
- Selar os dois cantos para garantir um selamento perfeito na frente.

6

- Fechar o softtop (o primeiro fecho é bastante difícil).
- Colar as tiras de tecido que fixam a capota aos 4 arcos intermédios.
- Verificar se as janelas fecham correctamente e se os selos estão no lugar.
- Voltar a montar o fecho traseiro (5).

Também vai gostar...



CAPOTAS MACIOS



**DEFLETORES DE
VIENTO**



PORTA-BAGAGENS



BAGAGENS A MEDIDA



ESTOFAMENTO



Comptoir du
Cabriolet



MANUAL DE MONTAGEM

BMW E30
1985 - 1993

Algumas dicas

- Trabalhar numa sala ventilada com uma temperatura ambiente de cerca de 20°C.
- Após a instalação, a capota deve ser deixada esticada durante vários dias.
- Não deixar a capota dobrada durante muito tempo.
- Ao dobrar a capota pela primeira vez, certifique-se de que acompanha o tecido durante todo o processo e que este se dobra correctamente para caber na caixa da capota.
- Recomendamos que coloque sempre um pano ou toalha de protecção sobre a janela traseira para evitar que seja danificada.

Também vai gostar...



CAPOTAS MACIOS



DEFLETORES DE VIENTO



PORTA-BAGAGENS



BAGAGENS A MEDIDA



ESTOFAMENTO



ACHTUNG

INFORMATIONEN

1/ KONTROLLE DES EMPFANGS INNERHALB VON 48 STUNDEN :

- Vergewissern Sie sich, dass Sie das richtige Produkt erhalten haben. Legen Sie das Verdeck über Ihr altes Verdeck und vergewissern Sie sich, dass das Produkt die richtige Größe und die gleichen Besonderheiten wie das vorhandene Verdeck hat.

**WIR WEISEN DARAUF HIN, DASS KEINE ARTIKEL MIT KLEBSTOFF- ODER VERLE-
GESPUREN ZURÜCKGENOMMEN WERDEN.**

- Vergewissern Sie sich, dass Sie das richtige Produkt erhalten haben. Legen Sie das Verdeck über Ihr altes Verdeck und vergewissern Sie sich, dass das Produkt die richtige Größe und die gleichen Besonderheiten wie das vorhandene Verdeck hat.

2 / KONTROLLE DES ZUSTANDS DER SCHLIESSGRIFFE :

- Überprüfen Sie, ob Ihre Griffe nicht gespalten sind:

Beim Anbringen des neuen Verdeckes ist das Spannen nämlich immer schwierig und erfordert einen starken Zug an den Griffen. Dieser Zug wird sehr schnell nachlassen, wenn das Verdeck seinen Platz eingenommen hat.

3/ ELEKTRISCHE VERDECKE :

VOR DER DEMONTAGE

- Überprüfen Sie, ob das System einwandfrei funktioniert, ob der Ölstand ausreichend ist und ob die Batterie geladen ist.

VOR DEM ZUSAMMENBAU (Verdeck abmontiert)

- Überprüfen Sie die Funktion des Überrollkäfigs.

- Reinigen und schmieren Sie alle Achsen.

- Wechseln Sie alle losen Gummibänder aus.

- Prüfen Sie, ob sich die einzelnen Bügel beim Abdecken normal in den Verdeckkasten falten lassen.

- Gegebenenfalls alle Gurte austauschen.

Wenn Sie diese Punkte nicht beachten, kann der Bügel Löcher in das Verdeck reißen.

4/ NICHT auf Lager gehaltene Waren oder SONDERBESTELLUNGEN :

- Sonderbestellungen und Produkte, die nicht auf Lager sind, werden weder zurückgenommen noch umgetauscht.

- Bei anderen Produkten, die nicht auf Lager sind, tragen Sie die Kosten für die Rücksendung sowie für die Kosten für eine eventuelle Prüfung und Neuverpackung.

- Das Produkt muss sich in neuem Zustand mit unverkratzten Folien in der Originalverpackung befinden.

Das könnte Sie auch interessieren...



WEICHE VERDECKE



WINDABWEISER



GEPACKABLAGE



MAßGESCHNEIDERTES
GEPACK



SATTLEREI



WARTUNGSBERATUNG VERDECKUNG

Sie haben ein Qualitätsprodukt erworben, dessen Qualitäten Sie schätzen werden, wenn es sorgfältig gepflegt wird. Dazu empfehlen wir Ihnen, die folgenden Hinweise zu beachten:

Pflegen Sie Ihren Überrollbügel

Wenn das alte Verdeck abmontiert wird, überprüfen Sie die Funktion und die Schmierung des Bügels, damit das neue Verdeck nicht beschädigt wird.

Kontrollieren Sie vierteljährlich die Funktion und die Schmierung des Überrollbügels mit dem Lösemittel.

Waschen Ihres Verdecks

Kondome dürfen nicht in der automatischen Rollenwaschanlage gewaschen werden.

Das Waschen der Verdecke sollte im Schatten und mit kaltem Wasser erfolgen.

Nachdem Sie das Verdeck gründlich nass gemacht haben, empfehlen wir Ihnen, das Verdeck mit den Reinigungsmitteln

RENOVO (Art.-Nr. DC01037 oder DC01038) und bürsten Sie das Verdeck mit der weichen Bürste ab.

Spülen Sie es anschließend gut ab.

Waschen Sie immer das gesamte Verdeck, um Ränder zu vermeiden.

Halten Sie das Verdeck geschlossen, bis es vollständig getrocknet ist.

Verwenden Sie keine chemischen Reinigungsmittel, die Aceton, Brennspritus, Benzin in allen Formen enthalten. in jeglicher Form, Verdüner, Entfettungsmittel, Lösungsmittel.....

Verwenden Sie nur Produkte, die von uns vertrieben werden und für deren Ergebnis und Wirkung wir garantieren. die Sicherheit.

Pflege der Rückscheibe aus weichem Kristallglas

Entriegeln Sie das Verdeck an der Vorderseite, bevor Sie den Reißverschluss bedienen.

Verwenden Sie keine chemischen Reinigungsmittel, die Aceton, Brennspritus, Benzin in jeglicher Form, Verdüner, Entfettungsmittel, Lösungsmittel.... enthalten.

Bedienen Sie Ihr Verdeck nicht, wenn die Temperatur unter 10° C liegt. Es besteht die Gefahr, dass Sie die weiche Heckscheibe aufreißen.

Wenn der Mechanismus elektrisch ist, empfehlen wir Ihnen, nach der Hälfte des Weges zu kontrollieren, ob das sich die weiche Heckscheibe richtig zusammenklappen lässt.

Waschen Sie die Lünette mit klarem Wasser und verwenden Sie dazu die Polierhülsen.

Reinigen und entfernen Sie Mikrokratzer, indem Sie die Polierhülsen verwenden, um den Glaserneuerer auf beiden Seiten aufzutragen.

Handhabung Ihres Verdecks

Bevor Sie Ihr Verdeck in den Kofferraum falten, sollten Sie sicherstellen, dass es sauber und vollkommen trocken ist. trocken ist. So vermeiden Sie Schrumpfung, Feuchtigkeitsflecken und Kratzer auf der Heckscheibe. weichen Heckscheibe.

Abdichten, Renovieren, Umfärben

Verwenden Sie nur Produkte, die von uns vertrieben werden und die sich bewährt haben.

Auf der Rückseite dieses Dokuments finden Sie die Kits, in denen alle Produkte aufgeführt sind, die in unserem in unserem Katalog enthalten sind.

Das könnte Sie auch interessieren...



WEICHE VERDECKE



WINDABWEISER



GEPACKABLAGE



MAßGESCHNEIDERTES
GEPACK



SATTLEREI



VORBEREITUNG LEGEN VERDECKUNG ANLEGEN

1/ DEN EMPFANG KONTROLLIEREN:

Vergewissern Sie sich, dass Sie das richtige Produkt erhalten haben:

Legen Sie das Verdeck über Ihr altes Verdeck und vergewissern Sie sich, dass das Produkt die richtige Größe hat und die gleichen Besonderheiten aufweist wie das vorhandene Verdeck.

WIR MÖCHTEN SIE DARAN ERINNERN, DASS KEINE ARTIKEL MIT KLEBSTOFF- ODER VERLEGESPUREN ZURÜCKGENOMMEN WERDEN.

2 / VORBEREITUNG DER WERKZEUGE :

Nietmaschine und passende Nieten.

Neoprenkleber und Pinsel.

Ein Maßband und eine Kreide.

Ein Hammer und ein Holzklötz.

Cutter mit großer und kleiner Klinge.

Universalzange

Maulschlüssel: 8/10/11/12/13.

Rohrschlüssel: 8/10/11/12/13.

Schlitz- und Kreuzschlitz-Schraubendreher.

3 / KONTROLLE DES ZUSTANDS DER SCHLIESSGRIFFE :

Überprüfen Sie, ob Ihre Griffe nicht gespalten sind:

Beim Anbringen des neuen Verdeckes ist das Spannen nämlich immer schwierig und erfordert einen starken Zug an den Griffen. Dieser Zug wird sehr schnell nachlassen, wenn das Verdeck seinen Platz eingenommen hat.

4 / ANBRINGEN DER PVC-VERDECKE :

PVC-Verdecke sollten in einer lauwarmen Umgebung aufgestellt werden, damit sie beim Aufstellen eine gute Flexibilität haben.

Im Sommer reicht es, sie in der Sonne liegen zu lassen.

Im Winter muss es mit einer Heißluftpistole erwärmt werden (Mindestabstand 20 cm, es sei denn, du kannst eine Lackierkabine benutzen).

ERSTES SCHLIESSEN DES PVC-Verdeckes: Das ist schwierig, Sie brauchen vielleicht zwei Personen, um das Verdeck zu schließen.

Personen, um das Verdeck zu schließen. Das ist normal. Am nächsten Tag hat es seinen Platz eingenommen und das Öffnen und Schließen ist problemlos möglich.

5 / WEICHE HECKSCHEIBE

Wenn sich auf der weichen Folie Spuren von Knicken befinden, können Sie diese wie folgt entfernen:

Mit einem Föhn, der mindestens 25 cm entfernt ist, erwärmen Sie die Stelle mit der Falte in kreisenden Bewegungen.

Sobald die Lünette weich wird, hören Sie auf zu heizen;

Lassen Sie die Brille abkühlen, während Sie an dem Tuch ziehen, das die weiche Brille umgibt, um die weiche Brille zu straffen, und streichen Sie die Falte weg.

Das könnte Sie auch interessieren...



WEICHE VERDECKE



WINDABWEISER



GEPACKABLAGE

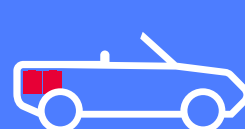

MAßGESCHNEIDERTES
GEPACK



SATTLEREI



MONTAGEANLEITUNG

BMW E30 1985 - 1993

WICHTIGE WARNUNG:

- Lesen Sie das gesamte Dokument, bevor Sie mit der Montage beginnen.
- Da dieses Dokument für erfahrene Fachleute erstellt wurde, sind einige Montageschritte nicht beschrieben.
- Die Garantie deckt keine Schäden ab, die durch unsachgemäße Montage verursacht werden.
- **Der Einbau durch einen Fachmann wird dringend empfohlen.**
- Bewahren Sie bei der Demontage alle Teile sorgfältig auf und notieren Sie sich ihre ursprüngliche Position, da sie bei der Montage des neuen Verdecks unerlässlich sind.
- Überprüfen Sie das Verdeck vor dem Einbau. **Bei Materialfehlern wenden Sie sich bitte an den Kundendienst, da das Verdeck nach dem Einbau weder zurückgenommen noch umgetauscht werden kann.**
- **Legen Sie die beiden Verdecke vor dem Einbau übereinander, um zu prüfen, ob die Abmessungen und Profile perfekt übereinstimmen;** bei Abweichungen wenden Sie sich an Ihren Kundendienst.

BEIM AUSWECHSELN DER VERDECKE MÜSSEN SIE UNBEDINGT DIE GURTE AUSTAUSCHEN.

Die verwendeten Gurte erlauben es nicht, das Verdeck im Verdeckkasten zu verstauen. Es besteht die Gefahr, dass der Stoff des Verdecks durch den Bügel durchstoßen wird.

Erforderliche Werkzeuge

- Schraubenzieher
- Bohrmaschine
- Nietpistole
- 7» Rohrzange
- Schneidegerät

Das könnte Sie auch interessieren...



WEICHE VERDECKE



WINDABWEISER



GEPACKABLAGE



MAßGESCHNEIDERTES
GEPACK



SATTLEREI



MONTAGEANLEITUNG

Comptoir du
Cabriolet

BMW E30
1985 - 1993

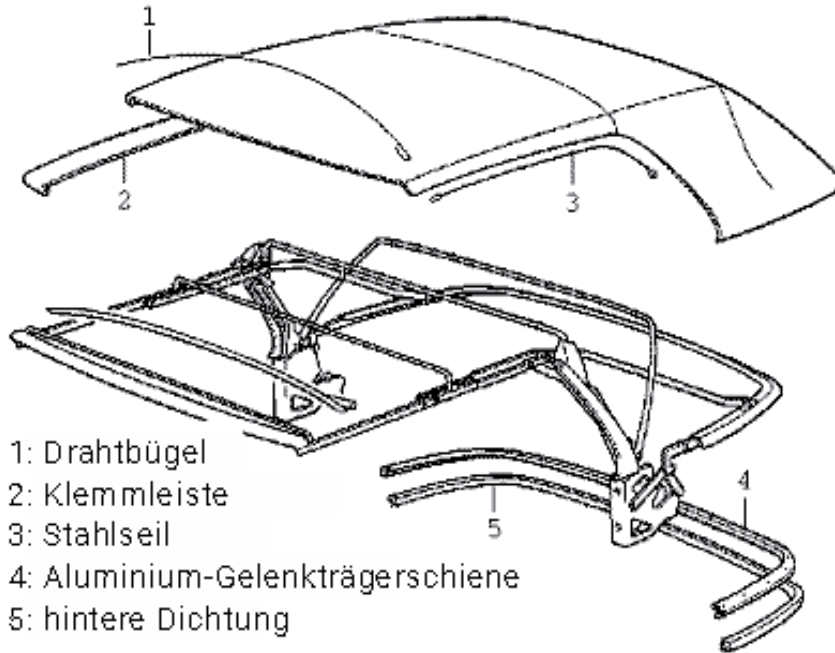

B1: vordere Schiene (ref 54311932704)

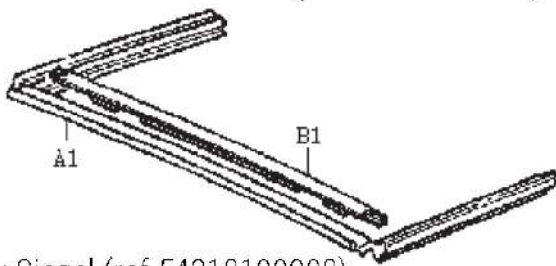

A1: Siegel (ref 54318100908)

A: Schiene
B: Siegel
C: Winkel



Das könnte Sie auch interessieren...



WEICHE VERDECKE



WINDABWEISER



GEPACKABLAGE



MAßGESCHNEIDERTES
GEPACK



SATTLEREI



**Comptoir du
Cabriolet**



MONTAGEANLEITUNG

BMW E30 1985 - 1993

1

- Entfernen Sie die vordere (U-förmige) Verschlussdichtung (A1), indem Sie sie zunächst aus den Schienen über den Seitenfenstern herausziehen.
- Fahren Sie mit der Vorderseite des Deckels fort (verwenden Sie ggf. einen Cutter, um die Dichtungsmasse zu schneiden, die die Dichtung in der Aluminiumschiene (B1) hält).
- Entfernen Sie die 5 Kreuzschlitzschrauben unter der Dichtung.
- Entfernen Sie die Schiene (B1).
- Nehmen Sie das Verdeck vom Deckel ab.

2

- Entfernen Sie die Seitenkabel oberhalb der Kante.
- Hängen Sie die Stahlseile aus, indem Sie den Haken mit einer Zange leicht öffnen.

3

- Wenn Sie ein elektrisches Verdeck haben, entfernen Sie den Drahtbügel (1), der sich zwischen dem Deckel und dem ersten Überrollbügel befindet.

4

- Entfernen Sie die 2 Hutmuttern, die die Halterung (C) hinter der Heckscheibendichtung halten.
- Entfernen Sie die Kreuzschlitzschraube, die das Gummiband hält.
- Entfernen Sie die Heckscheibendichtung (B) teilweise.
- Bohren Sie die Nieten unter der Heckscheibendichtung (B) auf und entfernen Sie die Dichtung und dann die Schiene (A).
- Ziehen Sie den Stoff des Verdecks unter der Schiene (A) ab.

Das könnte Sie auch interessieren...



WEICHE VERDECKE



WINDABWEISER



GEPACKABLAGE



**MAßGESCHNEIDERTES
GEPACK**



SATTLEREI



MONTAGEANLEITUNG

Comptoir du
Cabriolet

BMW E30
1985 - 1993

5

- Entfernen Sie die hintere Dichtung (5).
- Entfernen Sie die 9 Kreuzschlitzschrauben unter der hinteren Dichtung und entfernen Sie die Schiene (4).
- Entfernen Sie das Verdeck an den Zwischenbügeln.
- Schneiden Sie den Stoff an der Naht auf.
- Entfernen Sie den Stoff vom Überrollbügel.

EINBAU DES NEUEN VERDECKS

1

- Legen Sie das Verdeck auf den Rahmen, wobei beide Griffe geöffnet sein müssen.
- Setzen Sie das Verdeck provisorisch auf den Deckel.
- Positionieren Sie das Verdeck an der Rückseite.
- Kleben und positionieren Sie zunächst die Ecke auf dem Metallstift des Rahmens (fig.1).



- Zentrieren und positionieren Sie die Leinwand.
- Kleben und positionieren Sie die Seiten.

Das könnte Sie auch interessieren...



WEICHE VERDECKE



WINDABWEISER



GEPACKABLAGE



MAßGESCHNEIDERTES
GEPACK



SATTLEREI



Comptoir du
Cabriolet



MONTAGEANLEITUNG

BMW E30 1985 - 1993

2

- Kleben Sie die 2 Lagen Stoff auf die Rückseite der Schiene (4) und unter die Struktur.
- Kleben Sie den Stoff über die hintere Stange.
- Achten Sie darauf, dass der hintere Teil zentriert ist, das Ende des Stoffes muss nach unten zeigen.
- Bringen Sie die Verbindungsschiene (4) wieder an.

3

- Montieren Sie die Seitenkabel.
- Montieren Sie den vorderen Teil des Verdecks.



- Kleben und falten Sie den Stoff auf die Vorderseite.

Das könnte Sie auch interessieren...



WEICHE VERDECKE



WINDABWEISER



GEPACKABLAGE



MAßGESCHNEIDERTES
GEPACK



SATTLEREI



Comptoir du
Cabriolet



MONTAGEANLEITUNG

BMW E30 1985 - 1993

4

- Sobald der Kleber getrocknet ist, schließen Sie die Griffe an der Vorderseite und prüfen Sie die Spannung des Verdecks.
- Öffnen Sie das Verdeck und schließen Sie die seitliche Verklebung ab.
- Befestigen Sie die Schiene (A) wieder am Stoff, indem Sie eine Silikondichtung anbringen, dann bohren und nieten.
- Bringen Sie die Dichtung (B) wieder an der Schiene (A) an und vernieten Sie sie unten.
- Bohren Sie Löcher in den Stoff, damit die 2 Schrauben, die den Bügel (C) halten, durchgehen können, und bringen Sie die Hutmuttern an.
- Bringen Sie die Schraube, die das Gummiband hält, wieder an (die Originalverdecke haben eine Metallöse, wenn Ihr Verdeck nicht mit einer solchen ausgestattet ist, müssen Sie nur den Stoff verdoppeln und mit einem Locher ein Loch machen).

5

- Bringen Sie die vordere Schiene (B1) mit den 5 Kreuzschlitzschrauben wieder an, indem Sie vorher eine Silikondichtung anbringen.
- Bringen Sie die neue Frontdichtung an, indem Sie sie an jedem Ende 10 cm lang mit Silikon verkleben.
- Bringen Sie die Dichtung an den Seitenfenstern in den Aluminiumführungen an.
- Dichten Sie die beiden Ecken ab, um eine perfekte Dichtung an der Vorderseite zu gewährleisten.

6

- Schließen Sie das Verdeck (das erste Schließen ist etwas schwierig).
- Kleben Sie die Stoffstreifen, mit denen das Verdeck befestigt ist, an die 4 Zwischenbügel.
- Prüfen Sie, ob die Fenster richtig schließen und ob die Dichtungen richtig sitzen.
- Bringen Sie die hintere Dichtung (5) wieder an.

Das könnte Sie auch interessieren...



WEICHE VERDECKE



WINDABWEISER



GEPACKABLAGE



MAßGESCHNEIDERTES
GEPACK



SATTLEREI



Comptoir du
Cabriolet



MONTAGEANLEITUNG

BMW E30
1985 - 1993

Ein paar Tipps

- Arbeiten Sie in einem belüfteten Raum mit einer Umgebungstemperatur von etwa 20°C.
- Nach dem Einbau sollte das Verdeck mehrere Tage lang gespannt bleiben.
- Lassen Sie das Verdeck nicht über einen längeren Zeitraum gefaltet liegen.
- Wenn Sie das Verdeck zum ersten Mal falten, achten Sie darauf, dass Sie den Stoff während des gesamten Prozesses begleiten und dass er sich richtig faltet, damit er in den Verdeckkasten passt.
- Wir empfehlen Ihnen, immer ein Schutztuch oder Handtuch über die Heckscheibe zu legen, damit diese nicht beschädigt wird.

Das könnte Sie auch interessieren...



WEICHE VERDECKE



WINDABWEISER



GEPACKABLAGE



MAßGESCHNEIDERTES
GEPACK



SATTLEREI



ATTENZIONE INFORMAZIONI

1/ CONTROLLARE LA RICEZIONE ENTRO 48 ORE:

- Assicuratevi di aver ricevuto il prodotto corretto. Posizionate il soft top su quello vecchio e assicuratevi che il prodotto sia delle dimensioni giuste e abbia le stesse caratteristiche del soft top esistente.

Vi ricordiamo che nessun articolo che presenti tracce di colla o tracce di installazione verrà ritirato.

- Aprire la capote e lasciarla riposare a una temperatura vicina ai 20°.
- Se la capote non dispone di tutti gli accessori di cui è dotata la capote originale, tenerne conto al momento del rimontaggio.

2 / VERIFICARE LO STATO DELLE MANIGLIE DI CHIUSURA :

- Controllare che le maniglie non siano spaccate:
Quando si monta la nuova capote, il tensionamento è sempre difficile e richiede una forte trazione sulle maniglie. La tensione diminuisce molto rapidamente una volta che la capote è stata montata.

3/ SOFT TOP ELETTRICO :

PRIMA DELLO SMONTAGGIO

- Controllare che il sistema funzioni perfettamente, che il livello dell'olio sia soddisfacente e che la batteria sia ben carica.

PRIMA DEL RIASSEMBLAGGIO (capote rimossa)

- Controllare il funzionamento del roll bar.
- Pulire e lubrificare tutti i perni.
- Sostituire gli elastici allentati.
- Controllare che i vari cerchi si ripieghino normalmente nel box della capote quando questa viene rimossa.
- Se necessario, sostituire tutte le cinghie.

Se non si rispettano questi punti, il roll bar potrebbe forare la capote.

4/ Prodotti non disponibili in magazzino o in ordinazione speciale :

- Gli ordini speciali e i prodotti non disponibili in magazzino non possono essere restituiti o sostituiti.
- Per gli altri prodotti in stock, il costo della restituzione è a carico del cliente, così come il costo dell'ispezione e del reimpballaggio.
- Il prodotto deve essere in condizioni nuove, con i lucidi nella confezione originale.

Vi piacerà anche...



CAPOTE



FRANGIVENTO



PORTABAGAGLI

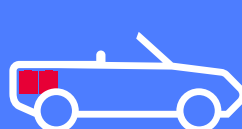

BAGAGLI SU
MISURA



SELLERIA



CONSIGLI PER LA MANUTENZIONE

COPERTURA

Avete appena acquistato un prodotto di qualità, di cui apprezzerete le qualità, a condizione che venga mantenuto con cura.

A tal fine, vi raccomandiamo di osservare le seguenti istruzioni:

Manutenzione del roll bar

Quando si rimuove la vecchia capote, controllare il funzionamento e la lubrificazione del roll bar per evitare di danneggiare la nuova capote. Ogni tre mesi controllare il funzionamento e la lubrificazione del roll bar utilizzando il Degrippant.

Lavaggio della capote

Non lavare le capote in un lavaggio automatico a rulli.

Le capote devono essere lavate all'ombra, con acqua fredda.

Dopo averla bagnata a fondo, si consiglia di spruzzare i detergenti RENOVO (sch. DC01037 o DC01038) e di spazzolare la capote con la spazzola morbida.

Successivamente, risciacquare bene.

Lavare sempre l'intera capote per evitare macchie.

Tenere il cofano chiuso finché non è completamente asciutto.

Non utilizzare detergenti chimici contenenti acetone, alcool metilato, benzina in qualsiasi forma, diluenti, sgrassanti o solventi....

Utilizzare solo prodotti da noi commercializzati e di cui garantiamo i risultati e la sicurezza.

Manutenzione del lunotto in cristallo morbido

Sbloccare la capote nella parte anteriore, prima di maneggiare la cerniera.

Non utilizzare detergenti chimici contenenti acetone, alcool metilato, benzina in qualsiasi forma, diluenti, sgrassanti o solventi.

Non maneggiare la cappottina quando la temperatura è inferiore a 10°. Si rischia di rompere il lunotto morbido.

Se il meccanismo è elettrico, si consiglia di controllare a metà viaggio che il lunotto morbido si ripieghi correttamente.

che il lunotto morbido si ripieghi correttamente.

Lavare il lunotto con acqua pulita utilizzando le maniche lucidanti.

Pulire e rimuovere i micrograffi, utilizzando le guaine lucidanti per applicare il rinnovatore per vetri morbidi su entrambi i lati.

Gestione della capote

Prima di ripiegare la capote nel bagagliaio, verificare che sia pulita e asciutta. In questo modo si eviteranno restringimenti, macchie di umidità e graffi sul lunotto morbido.

Impermeabilizzazione, ristrutturazione, ricolorazione

Utilizzate solo i prodotti che vendiamo e che si sono dimostrati validi.

Sul retro di questo documento troverete i kit che contengono tutti i prodotti descritti nel nostro catalogo.

Vi piacerà anche...



CAPOTE



FRANGIVENTO



PORTABAGAGLI

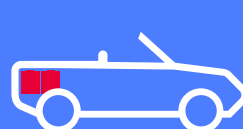

**BAGAGLI SU
MISURA**



SELLERIA



PREPARAZIONE INSTALLAZIONE INSTALLAZIONE DI UNA CAPOTE

1/ CONTROLLARE LA RICEZIONE:

Assicuratevi di aver ricevuto il prodotto corretto:
Presentate il soft top sopra il vostro vecchio soft top e assicuratevi che il prodotto sia delle dimensioni giuste e con le stesse caratteristiche del soft top esistente.

VI RICORDIAMO CHE NESSUN ARTICOLO CHE PRESENTI TRACCE DI COLLA O TRACCE DI INSTALLAZIONE VERRÀ RITIRATO.

2 / PREPARAZIONE DEGLI UTENSILI :

Rivettatrice e rivetti assortiti.	Taglierina a lama grande e piccola.
Colla e pennello per neoprene.	Pinze universali
Metro a nastro e gesso.	Chiave piatta: 8/10/11/12/13.
Martello e cuneo di legno.	Chiave per tubi: 8/10/11/12/13.
	Cacciavite piatto e a croce.

3 / CONTROLLARE LO STATO DELLE MANIGLIE DI CHIUSURA :

Controllare che le maniglie non siano spaccate:
Quando si monta la nuova capote, il tensionamento è sempre difficile e richiede una forte trazione sulle maniglie. La tensione diminuisce molto rapidamente una volta che la capote è stata montata.

4 / INSTALLAZIONE DI TOP IN PVC :

I top in PVC devono essere installati in un ambiente caldo, in modo che siano flessibili durante la posa.

In estate è sufficiente lasciarlo al sole. In inverno, va riscaldato con una pistola termica (distanza minima 20 cm. A meno che non si possa utilizzare una cabina di verniciatura).

PRIMA CHIUSURA DEL TOP IN PVC: Sarà difficile, potrebbero essere necessarie due persone per chiudere la capote. È normale. Il giorno dopo avrà ripreso il suo posto e la manovra di apertura o chiusura si svolgerà senza problemi.

5 / LUNETTO MORBIDO

Se la trasparenza morbida presenta delle pieghe, è possibile rimuoverle come segue:
Con un asciugacapelli posto ad almeno 25 cm di distanza, riscaldare la parte che presenta la piega con un movimento circolare.

Non appena la lunetta diventa morbida, interrompere il riscaldamento;

Lasciare raffreddare la lunetta tirando il tessuto che delimita la lunetta morbida per stringerla e cancellare la piega.

Vi piacerà anche...



CAPOTE



FRANGIVENTO



PORTABAGAGLI



**BAGAGLI SU
MISURA**



SELLERIA



MANUALE DI MONTAGGIO

BMW E30

1985 - 1993

AVVISO IMPORTANTE:

- Leggere l'intero documento prima di iniziare il montaggio.
- Poiché questo documento è stato realizzato per professionisti esperti, alcune fasi di montaggio non sono descritte.
- La garanzia non copre i danni causati da un'installazione non corretta.
- **Si raccomanda vivamente di affidare l'installazione a un professionista.**
- Durante lo smontaggio, conservare con cura tutte le parti e annotarne la posizione originale: saranno indispensabili per il montaggio della nuova capote.
- Ispezionare la capote prima del montaggio, se ci sono imperfezioni nel materiale contattare il servizio clienti, **la capote non potrà essere restituita o sostituita dopo il montaggio.**
- **Prima del montaggio, posizionare i due soft top l'uno sull'altro per verificare che le dimensioni e i profili corrispondano perfettamente;** in caso di differenze, contattare il servizio clienti.

IT IS IMPERATIVE THAT YOU CHANGE THE STRAPS WHEN REPLACING THE SOFT TOPS.

The used straps do not allow the soft top to be stored in the soft top box. There is a risk that the soft top fabric will be punctured by the hoop.

Tools required

- Screwdriver
- Drill
- Rivet gun
- 7» pipe spanner
- Cutter

Vi piacerà anche...



CAPOTE



FRANGIVENTO



PORTABAGAGLI



BAGAGLI SU
MISURA



SELLERIA



Comptoir du
Cabriolet



MANUALE DI MONTAGGIO

BMW E30

1985 - 1993

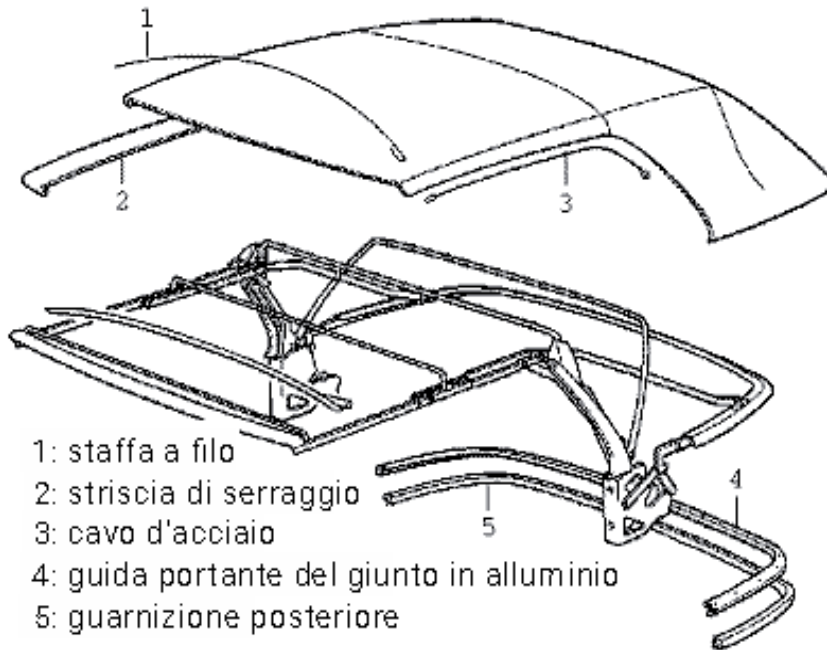

B1: binario anteriore (ref 54311932704)

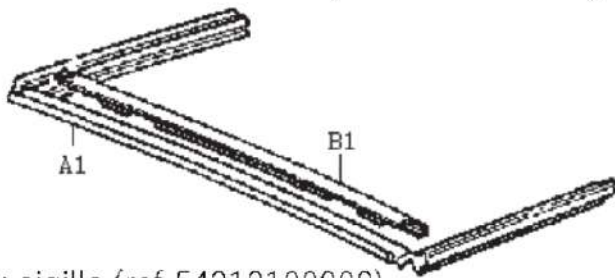

A1: sigillo (ref 54318100908)

A: rotaia

B: sigillo

C: piazza



Vi piacerà anche...



CAPOTE



FRANGIVENTO



PORTABAGAGLI



BAGAGLI SU
MISURA



SELLERIA



Comptoir du
Cabriolet



MANUALE DI MONTAGGIO

BMW E30

1985 - 1993

1

- Remove the front closure (U-shaped) seal (A1) by first pulling it out of the rails above the side windows.
- Continue with the front of the cap (use a cutter if necessary to cut the sealant holding the gasket in the aluminium rail (B1)).
- Remove the 5 crosshead screws under the seal.
- Remove the rail (B1).
- Remove the soft top from the cap.

2

- Remove the side cables above the edge.
- Unhook the steel cables by slightly opening the hook with pliers.

3

- If you have a power soft top, remove the wire bracket (1) located between the cap and the first roll bar.

4

- Remove the 2 cap nuts that hold the bracket (C) behind the rear window seal.
- Remove the Phillips screw holding the elastic band.
- Partially remove the rear window seal (B).
- Drill out the rivets under the rear window seal (B) and remove the seal and then the rail (A).
- Peel off the soft top fabric under the rail (A).

Vi piacerà anche...



CAPOTE



FRANGIVENTO



PORTABAGAGLI



**BAGAGLI SU
MISURA**



SELLERIA



Comptoir du
Cabriolet



MANUALE DI MONTAGGIO

BMW E30

1985 - 1993

5

- Remove the rear seal (5).
- Remove the 9 Phillips screws under the rear seal and remove the rail (4).
- Remove the soft top at the intermediate hoops.
- Cut the fabric at the seam.
- Remove the fabric from the roll bar.

FITTING THE NEW SOFT TOP

1

- Place the soft top on the frame with both handles open.
- Place the soft top provisionally on the cap.
- Position the soft top at the rear side.
- First glue and position the corner on the metal pin of the frame (fig.1).

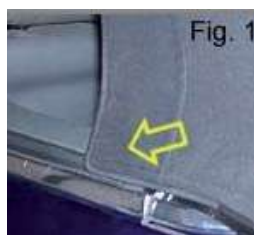

- Centre and position the canvas.
- Glue and position the sides.

Vi piacerà anche...



CAPOTE



FRANGIVENTO



PORTABAGAGLI



BAGAGLI SU
MISURA



SELLERIA



**Comptoir du
Cabriolet**



MANUALE DI MONTAGGIO

BMW E30

1985 - 1993

2

- Glue the 2 layers of fabric on the back of the rail (4) and under the structure.
- Glue the fabric covering the rear bar.
- Check that the rear section is centred, the end of the fabric must point downwards.
- Refit the joint rail (4).

3

- Fit the side cables.
- Fit the front part of the soft top.



- Glue and fold the fabric to the front.

Vi piacerà anche...



CAPOTE



FRANGIVENTO



PORTABAGAGLI



**BAGAGLI SU
MISURA**



SELLERIA



**Comptoir du
Cabriolet**



MANUALE DI MONTAGGIO

BMW E30 1985 - 1993

4

- As soon as the glue has dried, close the handles at the front and check the tension of the soft top.
- Open the soft top and finish the side gluing.
- Refit the rail (A) to the fabric by making a silicone seal, then drill and rivet.
- Refit the seal (B) in the rail (A) and fix it at the bottom.
- Drill holes in the fabric to allow the 2 screws holding the bracket (C) to pass through and fit the cap nuts.
- Refit the screw holding the elastic band (the original soft tops have a metal eyelet, if your soft top is not equipped with one, you just need to double the fabric and make a hole with a punch).

5

- Refit the front rail (B1) with the 5 crosshead screws, making a silicone seal beforehand.
- Place the new front seal by gluing it with silicone over 10cm at each end.
- Place the seal at the side windows in the aluminium guides.
- Seal the two corners to ensure a perfect seal at the front.

6

- Close the soft top (the first closing is rather difficult).
- Glue the fabric strips that secure the soft top to the 4 intermediate hoops.
- Check that the windows close properly and that the seals are in place.
- Refit the rear seal (5).

Vi piacerà anche...



CAPOTE



FRANGIVENTO



PORTABAGAGLI



**BAGAGLI SU
MISURA**



SELLERIA



Comptoir du
Cabriolet



MANUALE DI MONTAGGIO

BMW E30

1985 - 1993

A few tips

- Work in a ventilated room with an ambient temperature of about 20°C.
- After installation, the soft top should be left taut for several days.
- Do not leave the soft top folded for a long time.
- When folding the soft top for the first time, make sure that you accompany the fabric during the entire process and that it folds correctly to fit into the soft top box.
- We recommend that you always place a protective cloth or towel over the rear window to prevent it from being damaged.

Vi piacerà anche...



CAPOTE



FRANGIVENTO



PORTABAGAGLI



**BAGAGLI SU
MISURA**



SELLERIA