

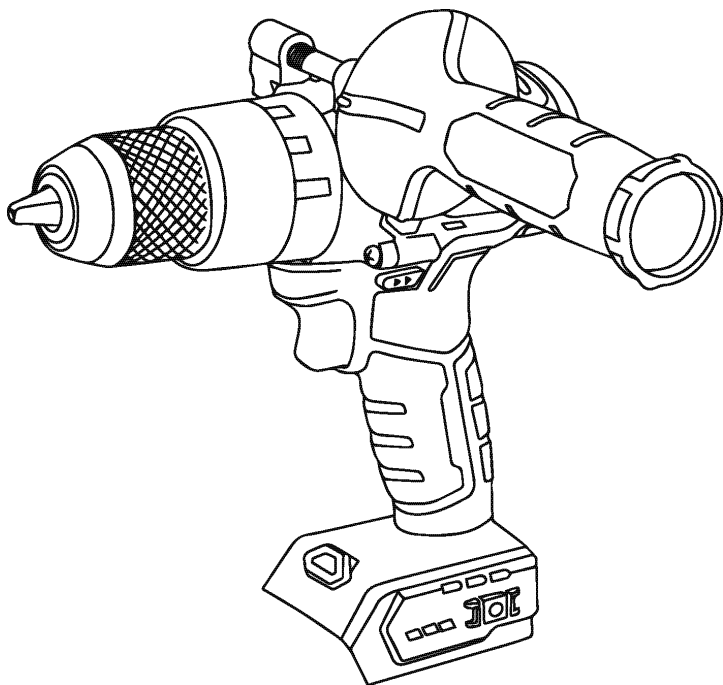

**PERCEUSE VISSEUSE SANS FIL 20V
À PERCUSSION TOOLATELIER
- 2000 TRS/MINUTE**

TA00500

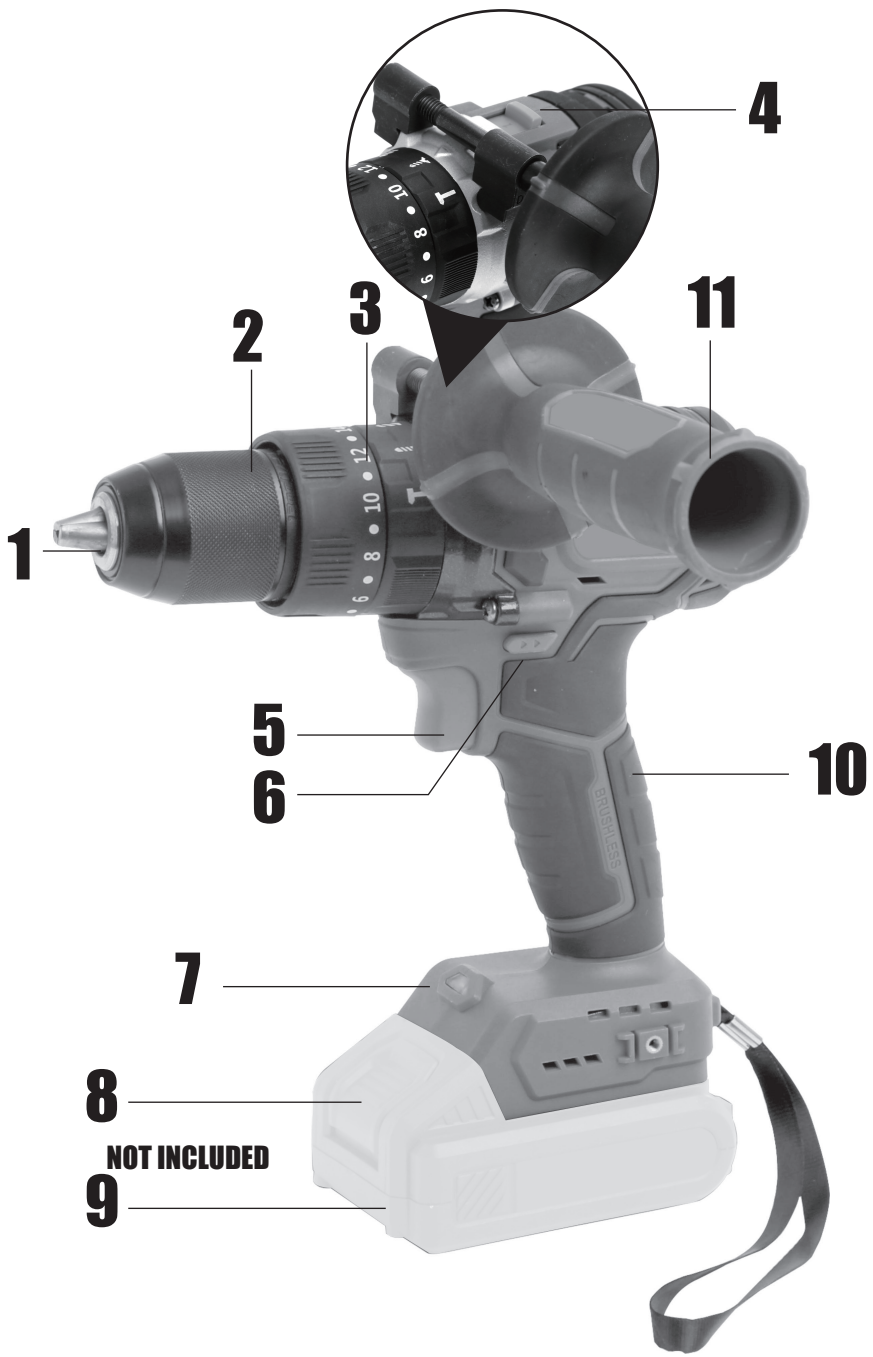

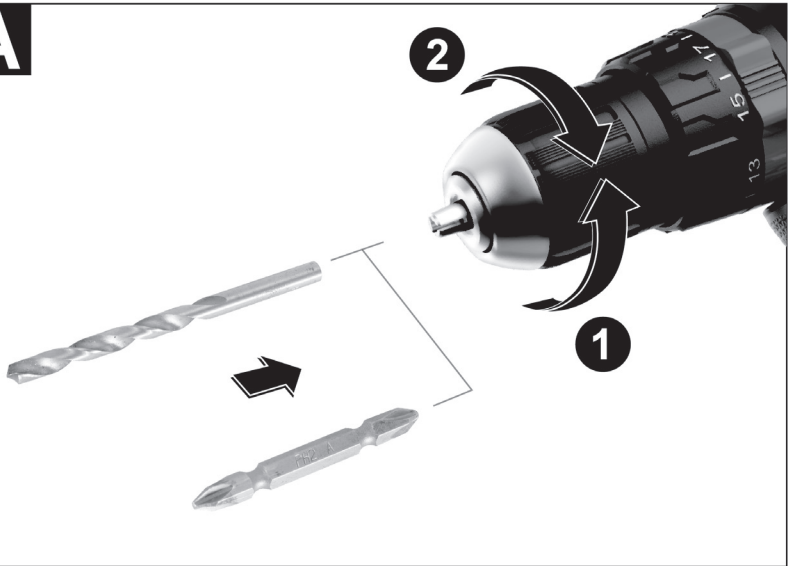
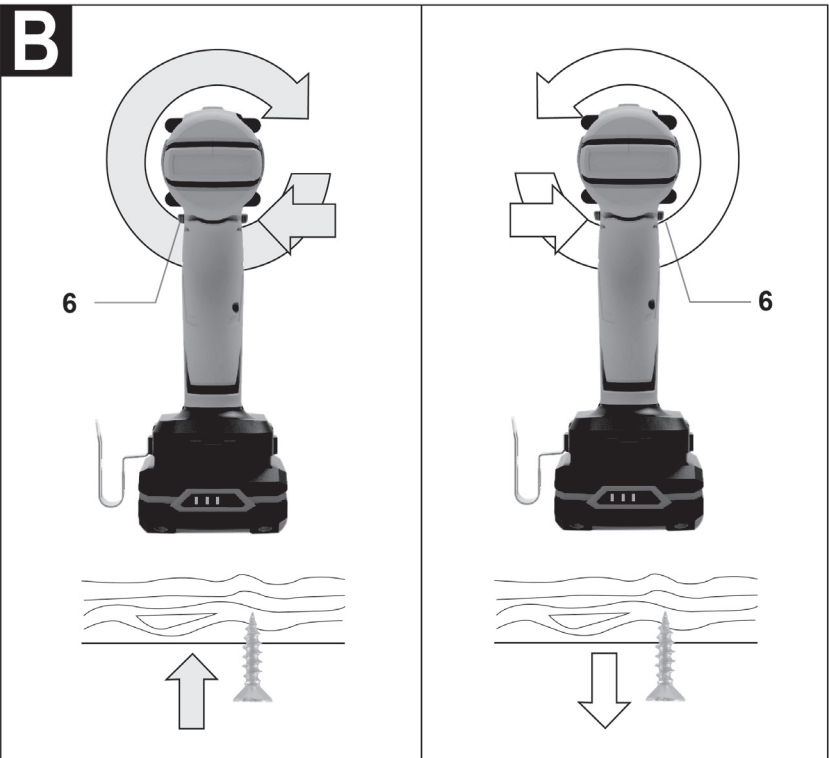

A**B**

English

Safety Notes

General Power Tool Safety Warnings

! **WARNING** Read all safety warnings and all instructions.

Failure to follow the warnings and instructions may result in electric shock, fire and/or serious injury.

Save all warnings and instructions for future reference. The term “power tool” in the warnings refers to your mains- operated (corded) power tool or battery-operated (cordless) power tool.

Work area safety

- ▶ **Keep work area clean and well lit.** Cluttered or dark areas invite accidents.
- ▶ **Do not operate power tools in explosive atmospheres, such as in the presence of flammable liquids, gases or dust.** Power tools create sparks which may ignite the dust or fumes.
- ▶ **Keep children and bystanders away while operating a power tool.** Distractions can cause you to lose control.

Electrical safety

- ▶ **Power tool plugs must match the outlet. Never modify the plug in any way. Do not use any adapter plugs with earthed (grounded) power tools.** Unmodified plugs and matching outlets will reduce risk of electric shock.
- ▶ **Avoid body contact with earthed or grounded surfaces, such as pipes, radiators, ranges and refrigerators.** There is an increased risk of electric shock if your body is earthed or grounded.
- ▶ **Do not expose power tools to rain or wet conditions.** Water entering a power tool will increase the risk of electric shock.
- ▶ **Do not abuse the cord. Never use the cord for carrying, pulling or unplugging the power tool. Keep cord away from heat, oil, sharp edges and moving parts.** Damaged or entangled cords increase the risk of electric shock.
- ▶ **When operating a power tool outdoors, use an extension cord suitable for outdoor use.** Use of a cord suitable for outdoor use reduces the risk of electric shock.
- ▶ **If operating a power tool in a damp location is unavoidable, use a residual current device (RCD) protected supply.** Use of an RCD reduces the risk of electric shock.

Personal safety

- ▶ **Stay alert, watch what you are doing**

and use common sense when operating a power tool. **Do not use a power tool while you are tired or under the influence of drugs, alcohol or medication.**

A moment of inattention while operating power tools may result in serious personal injury.

- ▶ **Use personal protective equipment. Always wear eye protection.** Protective equipment such as dust mask, nonskid safety shoes, hard hat, or hearing protection used for appropriate conditions will reduce personal injuries.
- ▶ **Prevent unintentional starting. Ensure the switch is in the off-position before connecting to power source and/or battery pack, picking up or carrying the tool.** Carrying power tools with your finger on the switch or energising power tools that have the switch on invites accidents.
- ▶ **Remove any adjusting key or wrench before turning the power tool on.** A wrench or a key left attached to a rotating part of the power tool may result in personal injury.
- ▶ **Do not overreach. Keep proper footing and balance at all times.** This enables better control of the power tool in unexpected situations.
- ▶ **Dress properly. Do not wear loose clothing or jewellery. Keep your hair, clothing and gloves away from moving parts.** Loose clothes, jewellery or long hair can be caught in moving parts.
- ▶ **If devices are provided for the connection of dust extraction and collection facilities, ensure these are connected and properly used.** Use of dust collection can reduce dust-related hazards.

Power tool use and care

- ▶ **Do not force the power tool. Use the correct power tool for your application.** The correct power tool will do the job better and safer at the rate for which it was designed.
- ▶ **Do not use the power tool if the switch does not turn it on and off.** Any power tool that cannot be controlled with the switch is dangerous and must be repaired.
- ▶ **Disconnect the plug from the power source and/or the battery pack from the power tool before making any adjustments, changing accessories, or storing power tools.** Such preventive safety measures reduce the risk of starting the power tool accidentally.

- ▶ **Store idle power tools out of the reach of children and do not allow persons unfamiliar with the power tool or these instructions to operate the power tool.** Power tools are dangerous in the hands of untrained users.
- ▶ **Maintain power tools. Check for misalignment or binding of moving parts, breakage of parts and any other condition that may affect the power tool's operation. If damaged, have the power tool repaired before use.** Many accidents are caused by poorly maintained power tools.
- ▶ **Keep cutting tools sharp and clean.** Properly maintained cutting tools with sharp cutting edges are less likely to bind and are easier to control.
- ▶ **Use the power tool, accessories and tool bits etc. in accordance with these instructions, taking into account the working conditions and the work to be performed.** Use of the power tool for operations different from those intended could result in a hazardous situation.

Battery tool use and care

- ▶ **Recharge only with the charger specified by the manufacturer.** A charger that is suitable for one type of battery pack may create a risk of fire when used with another battery pack.
- ▶ **Use power tools only with specifically designated battery packs.** Use of any other battery packs may create a risk of injury and fire.
- ▶ **When battery pack is not in use, keep it away from other metal objects, like paper clips, coins, keys, nails, screws or other small metal objects, that can make a connection from one terminal to another.** Shorting the battery terminals together may cause burns or a fire.
- ▶ **Under abusive conditions, liquid may be ejected from the battery; avoid contact. If contact accidentally occurs, flush with water. If liquid contacts eyes, additionally seek medical help.** Liquid ejected from the battery may cause irritation or burns.

Service

- ▶ **Have your power tool serviced by a qualified repair person using only identical replacement parts.** This will ensure that the safety of the power tool is maintained.

Safety Warnings for Drills and Screw-

drivers

- ▶ **Wear ear protectors when impact drilling.** Exposure to noise can cause hearing loss.
- ▶ **Hold power tool by insulated gripping surfaces when performing an operation where the cutting accessory or fastener may contact hidden wiring.** Cutting accessory and fasteners contacting a "live" wire may make exposed metal parts of the power tool "live" and could give the operator an electric shock.
- ▶ **Use auxiliary handle(s), if supplied with the tool.** Loss of control can cause personal injury.
- ▶ **Use appropriate detectors to determine if utility lines are hidden in the work area or call the local utility company for assistance.** Contact with electric lines can lead to fire and electric shock. Damaging a gas line can lead to explosion. Penetrating a water line causes property damage.
- ▶ **Switch off the power tool immediately when the tool is jams. Be prepared for high reaction torque that can cause kickback.**

- the power tool is subject to overload or
- it becomes wedged in the workpiece.
- ▶ **Hold the machine with a firm grip.** High reaction torque can briefly occur while driving in and loosening screws.
- ▶ **Secure the workpiece.** A workpiece clamped with clamping devices or in a vice is held more secure than by hand.
- ▶ **Always wait until the machine has come to a complete stop before placing it down.** The tool insert can jam and lead to loss of control over the power tool.
- ▶ **Do not open the battery.** Danger of short-circuiting.



Protect the battery against heat, e. g., against continuous intense sunlight, fire, water, and moisture. Danger of explosion.

- ▶ **In case of damage and improper use of the battery, vapours may be emitted. Ventilate the area and seek medical help in case of complaints.** The vapours can irritate the respiratory system.
- ▶ **Use the battery only in conjunction with your RAPTOR power tool.** This measure alone protects the battery against dangerous overload.
- ▶ **The battery can be damaged by pointed objects such as nails or screwdrivers or by force applied externally.** An inter-

nal short circuit can occur and the battery can burn, smoke, explode or overheat.

- ▶ **The battery is supplied partially charged. To ensure full battery capacity, completely charge the battery in the battery charger before using for the first time.**
- ▶ **Read the operating instructions of the battery charger.**
- ▶ **Adjust the gear switch only when the machine is at a complete stop.**
- ▶ **Always push the gear selector and turn the operating mode selector switch through to the stop.** Otherwise, the machine can become damaged.

Product Description and Specifications



Read all safety warnings and all instructions. Failure to follow the warnings and instructions may result in electric shock, fire and/or serious injury.

Intended Use

The machine is intended for driving in and loosening screws as well as for drilling in wood, metal, ceramics and plastic. Impact drills are additionally intended for impact drilling in bricks, brickwork and masonry.

The light of this power tool is intended to illuminate the power tool's direct area of working operation and is not suitable for household room illumination.

Product Features

The numbering of the product features refers to the illustration of the machine on the graphics page.

- (1) Tool holder
- (2) Keyless chuck
- (3) Torque presetting ring
- (4) Gear selector switch
- (5) On/off switch
- (6) Rotational direction switch
- (7) Work light
- (8) Battery release button(NOT INCLUDED)
- (9) Battery(NOT INCLUDED)
- (10) Handle (insulated gripping surface)
- (11) Additional handle

Technical Data

Model	TA00500
Voltage	20V
Chuck size	φ1.5mm-13mm
Speed	0-500/0-2000rpm
Max.torque	75N.m
Torque setting	20+3
Weight	1kg
Compatible battery (availability may vary)	2Ah 4Ah NOT INCLUDED 5Ah
Compatible charger (availability varies by package)	2.5A 4.0A NOT INCLUDED

Assembly

Battery Charging

Note: The battery supplied is partially charged. To ensure full capacity of the battery, completely charge the battery in the battery charger before using your power tool for the first time.

The lithium ion battery can be charged at any time without reducing its service life. Interrupting the charging procedure does not damage the battery.

The lithium-ion battery is protected against deep discharging. When the battery is empty, the machine is switched off by means of a protective circuit: The inserted tool no longer rotates.

- ▶ **Do not continue to press the On/Off switch after the machine has been automatically switched off.** The battery can be damaged.

Removing the battery

The battery is equipped with two locking levels that should prevent the battery from falling out when pushing the battery unlocking button unintentionally. As long as the battery is inserted in the power tool, it is held in position by means of a spring.

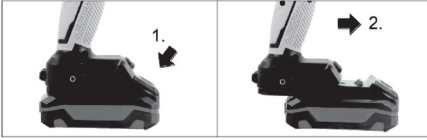

To remove the battery, press the unlocking button to remove the battery, press the unlocking button and pull out the battery toward the front.

Do not exert any force.

Changing the Tool (see figure A)

► **Before any work on the machine itself (e. g. maintenance, tool change, etc.) as well as during transport and storage, remove the battery from the power tool.**

There is danger of injury when unintentionally actuating the On/Off switch.

Open the keyless chuck by turning in rotation direction ①, until the tool can be inserted. Insert the tool.

Firmly tighten the collar of the keyless chuck by hand in rotation direction ②. This automatically locks the drill chuck.

Dust/Chip Extraction

► **Dust from materials such as lead-containing coatings, some wood types, minerals and metal can be harmful to one's health and cause allergic reactions, lead to respiratory infections and/or cancer.** Materials containing asbestos may only be worked by specialists.

- Provide for good ventilation of the working place.
- It is recommended to wear a P2 filter-class respirator. Observe the relevant regulations in your country for the materials to be worked.

► **Prevent dust accumulation at the workplace.** Dust can easily ignite.

Operation

Starting Operation

Inserting the battery

Note: Use of batteries not suitable for the machine can lead to malfunctions of or cause damage to the power tool.

Set the rotational direction switch to the centre position in order to avoid unintentional starting. Insert the charged battery into the handle so that it can be felt to engage and faces flush

against the handle.

Reversing the rotational direction (see figure B)

The rotational direction switch is used to reverse the rotational direction of the machine. However, this is not possible with the On/Off switch actuated.

Rotate clockwise: Move the rotational direction switch on both sides up to the stop into position ◀.

Rotate anticlockwise: Move the rotational direction switch on both sides up to the stop into position ▶.

Setting the operating mode



Drilling

Set the operating mode selector switch to the "drilling" symbol.

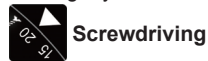

Screwdriving

Set the torque selector setting ring to the "screwdriving" symbol.

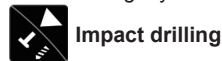

Impact drilling

Set the operating mode selector switch to the "impact drilling" symbol.

Switching On and Off

To **start** the machine, press the On/Off switch and keep it pressed.

The LED light up when the On/Off switch is halfway or fully pressed, and enables illumination of the screwing location in unfavorable light conditions.

Adjusting the Speed

The speed of the switched-on power tool can be variably adjusted, depending on how far the On/Off switch is pressed.

Light pressure on the On/Off switch results in a low rotational speed. Further pressure on the switch results in an increase in speed.

Setting the torque

With the torque preselection ring, the required torque can be preselected in 20 steps. The inserted tool is stopped as soon as the set torque is reached.

Gear selection, mechanical

► **The gear selector can be actuated at standstill or when the machine is running. However, this should not be done while operating at full load or maximum speed.**



1st gear:

Low speed range; for working with large drill-diameters.



2nd gear:

High speed range; for drilling with small drilling diameter.

Temperature Dependent Overload Protection

When using as intended for, the power tool cannot be subject to overload. When the load is too high or the allowable battery temperature range is exceeded, the speed is reduced. The power tool will not run at full speed until reaching the allowable battery temperature.

Protection Against Deep Discharging

The lithium-ion battery is protected against deep discharging. When the battery is empty, the machine is switched off by means of a protective circuit: The inserted tool no longer rotates.

Working Advice

- ▶ **Apply the power tool to the screw only when it is switched on** Rotating tool inserts can slip

An auxiliary tool can be used to remove the screwdriver bit or universal bit holder.

Belt Clip

With the belt clip, the machine can be hung onto a belt. The user has both hands free and the machine is always at hand.

Maintenance and Service

Maintenance and Cleaning

- ▶ **Before any work on the machine itself (e. g. maintenance, tool change, etc.) as well as during transport and storage, remove the battery from the power tool.** There is danger of injury when unintentionally actuating the On/Off switch.
- ▶ **For safe and proper working, always keep the machine and ventilation slots clean.**

Dispose of waste

Damaged power tools, batteries, accessories and waste packaging materials must be recycled and reused in an environmentally friendly manner.



Do not throw power tools and accumulators / batteries into general household waste!

TERMS OF WARRANTY SERVICE

1. This Warranty Certificate is the only document that confirms your right to free warranty service. Without presenting this certificate, no claims are accepted. In case of loss or damage, the warranty certificate is not restored.
2. The warranty period for the electric machine is 12 months from the date of sale, during the warranty period the service department eliminates manufacturing defects and replaces parts that have failed due to the fault of the manufacturer free of charge. In the warranty repair, an equivalent operable product is not provided. Replaceable parts become property of service providers.
3. Only clean tool accompanied with the following duly executed documents: this Warranty Certificate, Warranty Card, with all fields filled out, bearing the stamp of the trade organization and the signature of the buyer, shall be accepted for warranty repair.
4. Warranty repair is not performed in the following cases:
 - in the absence of a Warranty Certificate and a Warranty Card or their incorrect execution;
 - with failure of both a rotor and a stator of the electric engine, charring or melting of primary winding of the welding machine transformer, charging or starting-charging device, with internal parts melting, burn down of electronic circuit boards;
 - if a Warranty Certificate or a Warranty Card does not correspond to this electric machine or to the form established by the supplier;
 - upon expiration of the warranty period;
 - at attempts of opening or repair of the electric machine outside the warranty workshop; making constructive changes and lubrication of the tool during the warranty period, as evidenced, for example, by the creases on the

spline parts of the fasteners of non-rotational parts.

- when using electric tools for production or other purposes connected with making a profit, as well as in case of malfunctions related to instability of the power network parameters exceeding the norms established by GOST;
- in the events of improper operation (use the electric machine for other than intended purposes, attachments to the electric machine of attachments, accessories, etc. not provided by the manufacturer);
- with mechanical damage to the case, power cord and in case of damages caused by aggressive agents and high and low temperatures, ingress of foreign objects in the ventilation grids of the electric machine, as well as in case of damage resulting from improper storage (corrosion of metal parts);
- natural wear and tear on the parts of the electric machine, as a result of long-term operation (determined on the basis of the signs of full or partial depletion of the specified mean life, great contamination, presence of rust outside and inside the electric machine, waste lubricant in the gearbox);
- use of the tool the purposes for other than specified in the operating instructions.
- mechanical damages to the tool;
- in the event of damages due to non-observance of the operating conditions specified in the instruction (see chapter "Safety Precautions" of the Manual).
- damage to the product due to non-observance of the rules of storage and transportation.

Preventive maintenance of electric machines (cleaning, washing, lubrication, replacement of anthers, piston and sealing rings) during the warranty period is a paid service.

The service life of the product is determined by the manufacturer and is 2 years from the date of manufacture.

The owner is notified of any possible violations of the above terms of warranty service upon completion of diagnostics in the service center.

The owner of the tool entrusts the diagnostic procedure to be conducted in the service center in his absence.

Do not operate the electric machine when there are signs of excessive heat, sparking, or noise in the gearbox. To determine the cause of the malfunction, the buyer should contact the warranty service center.

Malfunctions caused by late replacement of

carbon brushes of the engine are eliminated at the expense of the buyer.

5. The warranty does not cover:

- replacement accessories (accessories and components), for example: batteries, discs, blades, drill bits, borers, chucks, chains, sprockets, collet clamps, guide rails, tension and fastening elements, trimming device heads, base of grinding and belt sander machines, hexagonal heads, etc.,
- fast wearing parts, for example: carbon brushes, drive belts, seals, protective covers, guiding rollers, guides, rubber seals, bearings, toothed belts and wheels, shanks, brake belts, starter ratchets and ropes, piston rings, etc. Their replacement during the warranty period is a paid service;
- power cords, in case of damage to the insulation, power cords are subject to mandatory replacement without the consent of the owner (paid service);
- tool case.