



Fitting Instructions

TOWBAR

For **VW92**

CRAFTER PANEL VAN / CREWBUS
Vehicles with rear step and single rear wheels – 2017 on

MATERIAL

A	1	Cross Bar
B	1	Coupling Packer
E	8	M12 x 110mm, Bolts, Ø40 Flat Washers and Nyloc Nuts
G	4	3mm Washers
H	4	M6 Nyloc nuts
CB	2	M16 x 60mm Coupling Bolts, Nuts, Lock Washers
EP	1	ZEP35 Electrical plate

Note: This towbar must be used with either a Witter Towball (part number Z11, Z32 and Z46) or Class A50-1 or A50-X towball, which dimensionally conforms to A50-1 with a 'D' and 'S' value greater than or equal to that of the towbar.

Please refer to the vehicle specification for the trailer weight and nose limits, which must be observed.

FITTING

1. Remove plastic step from support frame, remove and discard the support frame retaining the 4 M6 screws.
2. Loosely attach Cross bar (A) to existing bushed holes in vehicle chassis using Bolts **E** with Flat Washers and Nyloc nuts.
3. Cut plastic step lower edge as shown below and refit towbar frame using original fixings and Nuts **H** with Washers **G**.
4. Torque all bolts to values listed below.

Recommended torque settings: Grade 8.8 bolts: M16 - 200 Nm.
Grade 10.9 bolts: M12 - 130 Nm

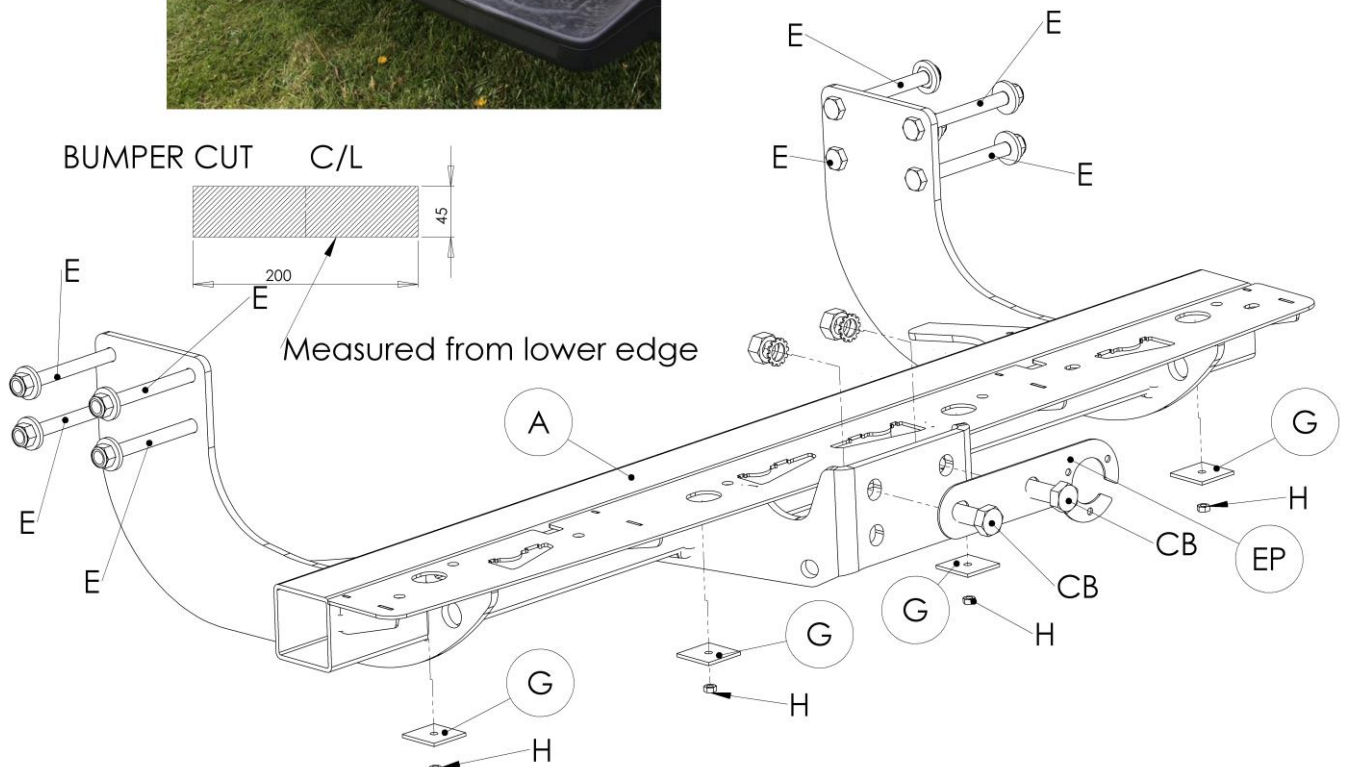

W0001MR35B-FIT\$021004060000